

DIGITAL RADIOGRAPHY

# CXDI-RF Wireless B1

Instructions for Use

---

# To customers

## Important information on usage and management of the product

- This product complies with local radio frequency regulations in the country or region where you purchased the product. Note that it cannot be used in any other areas. When using the product, follow the notes on radio frequency in this manual.
- Only a physician or a legally certified operator shall use the product.
- The product shall be maintained in a safe and operable condition by maintenance personnel.
- Note that the entire radiography system, including the product, is required to comply with IEC 60601-1. Therefore, please make sure that only ME equipment conforming to IEC standards is connected to the product. Connected medical equipment, such as X-ray generators, must comply with IEC 60601-1, and image-capture computers and displays must comply with IEC 60601-1 or IEC 62368-1. For further details, consult your sales representatives or local Canon dealers.
- Connection of a system that uses the product to a network could result risks to patients, operators, or third parties. A dedicated individual who is assigned responsibility for maintenance should assess these risks in advance. The responsible person should also assess the risks when changes to the network (including changes in the network configuration, addition or disconnection of items to the network, or update or upgrade of equipment connected to the network) occur after connection.

## Note on installation

- Request your sales representative or local Canon dealer to install the product.

## Notes on disposal of the product

- Disposal of this product in an unlawful manner may have a negative impact on human health and on the environment. Therefore, when disposing of this product, be absolutely certain to follow the procedure which conforms with the laws and regulations applicable to your area.



### Only for European Union and EEA (Norway, Iceland and Liechtenstein)

This symbol indicates that this product is not to be disposed of with your household waste, according to the WEEE Directive (2012/19/EU) and national legislation. This product should be handed over to a designated collection point, e.g., on an authorized one-for-one basis when you buy a new similar product or to an authorized collection site for recycling waste electrical and electronic equipment (EEE). Improper handling of this type of waste could have a possible negative impact on the environment and human health due to potentially hazardous substances that are generally associated with EEE. At the same time, your cooperation in the correct disposal of this product will contribute to the effective usage of natural resources. For more information about where you can drop off your waste equipment for recycling, please contact your local city office, waste authority, approved WEEE scheme or supplier where you purchased the product.

The information above, including information on batteries, is on our website in the official languages of each EU country.

Please access <https://global.canon/en/ifu/medcom/envfile/weee-battery-eu.pdf>.

### Only for the United Kingdom

This symbol indicates that this product is not to be disposed of with your household waste, according to the UK Waste Electrical and Electronic Equipment Regulations. This product should be handed over to a designated collection point, e.g., on an authorized one-for-one basis when you buy a new similar product or to an authorized collection site for recycling waste electrical and electronic equipment (EEE). Improper handling of this type of waste could have a possible negative impact on the environment and human health due to potentially hazardous substances that are generally associated with EEE. At the same time, your cooperation in the correct disposal of this product will contribute to the effective usage of natural resources. For more information about where you can drop off your waste equipment for recycling, please contact your local city office, waste authority, approved WEEE scheme or supplier where you purchased the product.

The information above, including information on batteries, is on our website. Please access <https://global.canon/en/ifu/medcom/envfile/weee-battery-uk.pdf>.

# 1 Safety information

## 1.1 Safety precautions

Follow these safeguards and properly use the equipment to prevent injury and damage to any equipment/data.

### Operating/storage environment

- **Do not use or store the equipment near flammable chemicals such as alcohol, thinner, benzine, etc.**  
**If chemicals are spilled or evaporate, it could result in fire or electric shock through contact with electric parts inside the equipment. Also, some disinfectants are flammable. Be sure to take care when using them.**
- **Do not connect the equipment with anything other than specified.**  
**Doing so could result in fire or electric shock.**
- **Do not install or store the equipment in any of the locations listed below.**  
**Doing so may result in failure or malfunction, equipment falling, or fire or injury.**
  - Close to facilities where water is used
  - Where it will be exposed to direct sunlight
  - Close to the air outlet of an air-conditioner or ventilation equipment
  - Close to a heat source such as a heater
  - Where the power supply is unstable
  - On the floor
  - In a dusty environment
  - In a saline or sulfurous environment
  - Where temperature or humidity is high
  - Where there is freezing or condensation
  - In areas prone to vibration
  - On an incline or in an unstable area
- **Be sure that the patient is in continuous contact with the surface of the detector for less than 10 minutes. Depending on the heat generated by the internal device, the temperature of the detector's surface may increase by up to 10°C. Avoid prolonged contact with the surface of the detector in order to decrease physical stress and the possibility of low-temperature burns due to contact with the patient's skin.**

- **When using the detector, if you observe an abnormal rise in temperature above the temperatures listed below, stop using it immediately and contact your sales representative or local Canon dealers.**

**The maximum temperature of the detector: 45°C\*.**

\* This is measured during Canon's maximum load test when the ambient temperature is set to 35°C.

### **Power supply and cables**

- **Do not place heavy object such as medical equipment on cables and cords, or do not pull, bend, bundle, or step on them to prevent their sheath from being damaged, and do not alter them neither.**

Doing so may damage the cords which could result in fire or electric shock.

- **Do not turn ON the power when condensation has formed on the equipment.**

Doing so could result in fire or electric shock.

- **When using the equipment's wiring cable, it becomes weakly magnetized. When exposing patients with cardiac pacemakers to X-rays, always make sure that the patients have no problems during exposure.**

If a problem occurs, keep the equipment's wiring cable away from the patients and consult your doctor.

- **Always connect the three-core power cord plug to a grounded AC power outlet.**

- **To make it easy to disconnect the plug at any time, avoid putting any obstacles near the outlet.**

Otherwise, it may not be possible to disconnect the plug in an emergency.

- **Because the equipment cable is long, take care that cables do not become tangled during use. Also, be careful not to get your feet caught in the cable.**

Otherwise, it may cause a failure of the equipment or the injury of the user due to tripping over the cable.

- **Do not charge a deteriorated battery.**

Using a battery that has exceeded its product life may lead to overheating, fire, or explosion.

- **Do not charge the battery when the equipment is covered with an object (such as a cloth).**

Doing so may result in overheating or fire.

### **Handling**

- **Do not place anything on top of the equipment.**

The object may fall and cause an injury. Also, if metal objects such as needles or clips fall into the equipment, or if liquid is spilled, it could result in fire or electric shock.

- **Do not hit or drop the equipment. Handle the equipment carefully as it is precision equipment.**

The equipment may be damaged if it receives a strong jolt, which could result in fire or electric shock if the equipment is used without being repaired.

- **Attach the battery pack carefully.**
- **Make sure that the battery pack is correctly attached.**
- **Have the patient take a fixed posture and do not let the patient touch parts unnecessarily.**

If the patient touches connectors or switches, it could result in electric shock or malfunction of the equipment.

- **Always confirm that there is no problem with the CXDI system or the patient during use. If a problem occurs, take appropriate measures, such as shutting down the system.**
- **Do not touch conductive parts of this equipment and the patient simultaneously. Otherwise, electric shock may result.**
- **Do not splash the patient's bodily fluids, medicines, water, etc. on any of the equipment.**

The detector provides dust proof and waterproof protection. However, note the following precautions before using the equipment. The ingress of water may damage the equipment and cause a fire or electric shock.

- Do not submerge the equipment in water for an extended period.
  - If the detector gets wet, use a dry soft cloth to wipe it completely dry.
  - Securely close and lock the battery cover. The dust proofing and waterproofing performance may be compromised if the cover is not locked.
  - Do not open or close the battery cover when there is dust on it or when the equipment is wet.
  - Do not use the detector if water droplets or dust get inside the battery bay.
  - If necessary, wrap the equipment in a disposable cover to prevent the risk of infection.
  - If the detector is bumped, dropped, or otherwise subjected to physical impact, the dust proofing and waterproofing performance may deteriorate.
  - The battery cover is a consumable item. If the battery cover is deformed or the packing is damaged or cracked, replace the battery cover with a new one. Continuing to use the battery cover in a deteriorated state may cause dust and water to penetrate the equipment.
  - The junction between the wiring cable and the Multi Box is not dust proof or waterproof.
- **Turn OFF the power to each piece of equipment for safety when not being used.**
  - **Do not place excessive weight on the equipment. Do not use the equipment in a manner that will subject it to local loads of 100 kg or more.**
- If the load exceeds the limit, the inner device may be damaged.
- **Do not touch the electrode terminals of the equipment and the battery pack.**

- **Be sure to use the equipment on a flat surface while using it in horizontal position.**

If the detector is set on a diagonal and pressure is applied to it, the inner device may be damaged.

- **Be sure to securely hold the equipment while using it in upright positions.**

Otherwise, the equipment may fall over, resulting in injury to the user or patient, or may flip over, resulting in damage to the inner device.

- **Be sure to use only the dedicated battery pack for this product.**

- **If battery liquid leaks and comes into contact with your skin or clothes, immediately wash it off with tap water, etc.**

The contact with the battery liquid may cause skin irritation.

- **While preparing for examinations, be sure to confirm that the entered information (patient name, ID number, date of birth, and sex) matches that of the patient.**

If the information is incorrect, the resulting patient mix-up and a misdiagnosis may cause harm to the patient.

- **Be sure to use the [Emergency] button only for an emergency examination.**

If not heeded, the resulting patient mix-up and a misdiagnosis may cause harm to the patient.

- **Instruct the patient not to move during the examination. If necessary, help the patient to maintain the proper posture.**

If the patient moves during the examination, it may fail to obtain the appropriate images.

#### **When a problem occurs**

- **Should any of the following occur, immediately turn OFF the power to each piece of equipment, unplug the power cord from the AC outlet, and contact your sales representative or local Canon dealer:**

- When there is smoke, an odd smell or abnormal sound
- When liquid has been spilled into the equipment or a metal object has entered through an opening
- When the equipment has been dropped and is damaged

### **Inspection, disinfection, and cleaning**

- **Do not use flammable solvents to clean the surface of the equipment.**

When the equipment is going to be cleaned, be sure to turn OFF the power to each piece of equipment, remove the battery pack, and unplug the power cord from the AC outlet. Never use alcohol, benzene, thinner or any other flammable solvents. Otherwise, it could result in fire.

- **Clean the plug of the power cord periodically by unplugging it from the AC outlet and removing dust or dirt from the plug, its periphery and AC outlet with a dry cloth.**

If the cord is kept plugged in for a long time in a dusty, humid or sooty place, dust around the plug will attract moisture, and this could cause insulation failure that could result in a fire.

- **After every examination, wipe the patient contact surfaces of the detector using a disinfectant such as disinfecting ethanol to prevent the risk of infection.**

A blood infection or other causes may result in the onset of an infectious disease. For details on how to disinfect, consult a specialist.

- **Do not spray the detector directly with disinfectants or detergents.**

- **Always keep this product and other equipment clean and remove all dust and dirt.**

Dust and dirt may cause malfunctions of the equipment included in the radiography system, such as this product and computers.

- **When cleaning the battery pack, wipe it with a cloth slightly dampened with water or diluted neutral detergent.**

The battery pack is not protected against liquids. When cleaning the battery pack, wipe it carefully so as not to spill the detergents onto the electrodes.

- **Dry the battery pack completely after cleaning, and attach it to the equipment.**

- **When cleaning any other parts than the sensor side of the detector, wipe them carefully so as not to spill the detergents onto the battery pack attachment portion (electrodes).**

- **Use water or diluted neutral detergent to clean the surface of the equipment and peripherals. Do not wipe the surface of the equipment or peripherals with solvents such as absolute alcohol, thinner, or benzene as they may cause damage.**

- **Dry the detector completely after disinfecting or cleaning it.**

## 1.2 Notes on radio frequency

This product complies with local radio frequency regulations in the country or region where you purchased the product. Note that it cannot be used in any areas other than the country or region of its purchase.

In the frequency band used by this product, not only industrial, scientific and medical equipment such as microwave ovens but also premises radio stations (license required) and specified low-power radio stations (license not required) for mobile object identification such as used in factory manufacturing lines, etc., and amateur radio stations (license required) may be in operation. Use of this product may cause radio interference with the above equipment and radio stations, so be sure to understand the following precautions before use.

- Before using this product, make sure that there are no premises radio stations and specified low-power radio stations for mobile object identification operating nearby.
- In the event that radio waves from this product cause harmful interference to premises radio stations for mobile object identification, immediately stop using the product and contact your sales representative or local Canon dealers.
- Also contact your sales representative or local Canon dealers if other problems occur, such as harmful radio interference from this product to specified low-power radio stations for mobile object identification or amateur radio stations.
- This product is suitable for use in hospital (professional healthcare facility) environments, with the exception of environments near active HF SURGICAL EQUIPMENT or the RF shielded room of an ME SYSTEM for magnetic resonance imaging, where the intensity of ELECTROMAGNETIC DISTURBANCES is high.
- **WARNING:**  
Use of this equipment adjacent to or stacked with other equipment should be avoided because it could result in improper operation. If such use is necessary, this equipment and the other equipment should be observed to verify that they are operating normally.
- To maintain the optimum EMD performance, use only the designated cables.
- **WARNING:**  
Use of equipment, transducers and cables other than those specified or provided by Canon sales representative or local Canon dealer could result in increased electromagnetic emissions or decreased electromagnetic immunity of this equipment and result in improper operation.
- **WARNING:**  
Portable RF communications equipment (including peripherals such as antenna cables and external antennas) should be used no closer than 30 cm (12 inches) to any part of the detector, including cables specified by Canon sales representative or local Canon dealer. Otherwise, degradation of the performance of this equipment could result.

### 1.3 Notes for using the equipment

When using the equipment, take the following precautions. Otherwise, problems may occur and the equipment may not function correctly.

#### Before use

---

- Sudden heating of the room in cold areas will cause condensation to form on the equipment. In this case, wait until the condensation evaporates before performing an exposure. If the equipment is used while condensation is formed on it, problems may occur. When an air-conditioner is used, be sure to raise/lower the temperature gradually so that a difference in temperature in the room and in the equipment does not occur, to prevent condensation.

#### During use

---

- To reduce exposure to RF energy, keep hands and other body parts out of close contact with the wireless aperture on the detector.
- Do not use the detector near devices generating a strong magnetic field. Doing so may produce image noise or artifacts.
- Avoid unnecessary exposure for patients, especially for children. For details, be sure to read the precautions on radiation protection in the manual for the connected X-ray generator.
- The Battery Charger is not protected (sealed) against liquids such as blood and medication in the operating room.
- Use the Battery Charger indoors.
- Do not install the ready indicator and IR data communication unit such a position that its IR data port faces the monitor, reflector, or other IR data communication equipment, except for the detector.
- Images and raw data stored on the recording medium in the equipment may become unreadable due to operation errors, equipment failure, or other unexpected events, so be sure to always store data on an external recording device (medium) or record it to film.

#### Disinfection and cleaning

---

- When disinfecting the patient contact surfaces of the detector, wipe them with a disinfecting cloth moderately dampened with a disinfectant such as disinfecting ethanol.
- When cleaning the detector, wipe it with a cloth slightly dampened with water or diluted neutral detergent.

#### Others

---

- Do not use this product in combination with other equipment such as defibrillators or large electric motors as these may cause power-supply noise or power supply voltage variations. Doing so may prevent normal operation of this product and other equipment.
- This product may malfunction due to electromagnetic waves caused by portable personal telephones, transceivers, radio-controlled toys, etc. Be sure to avoid having objects such as these, which affect this product, brought near the product.
- When the detector will not be used for some time, remove the battery pack. Otherwise, overdischarge may occur, leading to a shorter battery life.

## 2 Introduction

This device is indicated for use in generating radiographic images of human anatomy to replace the radiographic film/screen systems in all general purpose diagnostic procedures. It is also used for generating fluoroscopic images, when integrated into the X-ray diagnostic systems, to replace the spot-film devices and the X-ray image intensifiers. This device is not intended for mammography applications.

## 3 Operating procedures

### 3.1 Preparing to use the detector

- 1 **Charge the battery pack.**
- 2 **Attach the battery pack.**
  - i) Remove the battery cover.
  - ii) Attach the battery pack.
  - iii) Attach the battery cover.

### 3.2 Operating the detector

- 1 **Turn on the detector.**
- 2 **Register the detector and make connection to the CXDI control system.**
- 3 **Conduct examination.**
  - i) Select or register the patient information.
  - ii) Select the protocol.
  - iii) Press the exposure switch.
  - iv) Check the captured images.

### 3.3 Ending use of the detector



- 1 **Turn off the detector.**

## 3.4 List of detector status indication

Detector status	Status indicators	
	Power LED <sup>*1</sup>	READY LED
Power OFF	Not illuminated	Not illuminated
Power ON	Illuminated	Not illuminated
Linkage started	Illuminated	Flashing (3 sec. only) <sup>*2</sup>
Switching to exposure ready status	Illuminated	Flashing
Exposure ready status	Illuminated	Illuminated
Detector selection status (Sleep)	Illuminated	Not illuminated
Error	Flashing	Flashing

\*1 The indication of the Power LED lamps changes according to the remaining battery charge.

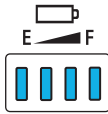
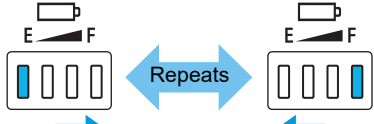
\*2 Only after linkage from the detector

Detector status	Power LED lamp
Power on <sup>*1</sup>	
Starting up <sup>*2</sup>	
Preparing to power off <sup>*3</sup>	 <p>Lamps light up one at a time</p> <p>Lamps light up one at a time</p> <p>(One full sequence, one second interval)</p>

\*1 When the battery pack is not attached

\*2 Until the operation of the switches is enabled after the POWER switch is pressed and held

\*3 Until the detector power turns off after the POWER switch is pressed and held

## 3.5 List of lights / flashes / notification beeps of the ready indicator

	Link (registration) completed	During exposure ready status	During exposure
		Start time	When the X-ray is exposed
LED lamp	The 2 LED lamps flash*1.	The 2 LED lamps light up weakly.	
Notification sound	Three-tone beep	Single beep	N/A

\*1 On/Off status changes three times every 0.5 seconds

## 3.6 Image processing adjustment

### To set the Elt value

Elt value can be set in the processing parameter edit screen of the CXDI Control Software. Enter a value in the Elt text box referring to the current EI value.

- EI (Exposure Index)  
EI is an approximative indicator of the dose that reaches the detector, as calculated per IEC 62494-1 standards from the captured images.
- Elt (Target Exposure Index)  
Elt is the target EI level.
- DI (Deviation Index)  
DI is a logarithmic index indicating the difference between the EI and Elt.

## 4 Troubleshooting

When you encounter problems described in this chapter or error messages in the CXDI Control Software while using this product, search the table in this chapter for the problem or error message and try the solutions.

If the problem persists, turn off the detector, consult your sales representative or local Canon dealer, and inform them of the details of the problem, error codes or error messages.

Symptom	Cause/Error messages in the CXDI Control Software	Remedy
Power LED lamps flash (1-second cycles) and exposure is not possible.	No battery power.	Replace the battery pack with a fully-charged one and retry an exposure.

# 5 Maintenance

## Maintenance and inspection

If any problem is found during the following inspections and cannot be resolved, please contact your sales representative or local Canon dealer.

### Daily inspection

#### Cable

---

- (1) Ensure that the cables are not damaged and the cable jackets are not torn so as to expose the inside of the cables.
- (2) Ensure that the power cord plugs are securely connected to both the equipment AC inlet and the AC outlet.
- (3) Ensure that there are no breaks or short-circuits in all pins of the detector connector plugs.
- (4) Ensure that there is no dust, dirt, or oil on the terminals of the wiring cable connector.

#### Detector

---

- (1) Ensure that there are no loose or missing screws.
- (2) Ensure that there are no break or no deformation on the exterior of the detector.
- (3) Ensure that there is no dust or foreign matter on the battery bay connector.
- (4) Ensure that there are no breaks or short-circuits in the battery bay connector.
- (5) Ensure that there is no dust, dirt, or oil on the terminals of the cable connector.
- (6) Ensure that the battery cover is not damaged or bent.
- (7) Ensure that there is nothing wrong with the rubber in the battery cover (foreign objects, tears, cracks, etc.).

#### After turning on the power

---

Be sure to start the CXDI Control Software before performing the following inspection.

- (1) Perform test exposure.  
Ensure that captured images are displayed normally on the monitor.

## Monthly inspection

- (1) Conduct a Performance Test.
- (2) Regularly conduct a Self-diagnosis.

## Yearly inspection

- (1) Perform a Performance Test or Self-diagnosis using a phantom or resolution chart, etc.
- (2) Check the EI value captured.

## Irregular inspection

- (1) Perform calibration in the following circumstances.
  - When exposure conditions have changed significantly
  - When images appear strange in some way
  - When the installation environment has changed significantly

# 6 Specifications

## 6.1 Main specifications

### Flat Panel Detector: AF-B1

Environmental requirements:

Operation

Temperature: 5°C to 35°C  
Humidity: 15% to 80% RH (without condensation)  
Atmospheric pressure: 613 to 1060 hPa

Storage (unpacked)

Temperature: 5°C to 40°C  
Humidity: 15% to 85% RH (without condensation)  
Atmospheric pressure: 613 to 1060 hPa

Transportation and storage (in packages at point of purchase)

Temperature: -30°C to 50°C  
Humidity: 10% to 95% RH (without condensation)  
Atmospheric pressure: 613 to 1060 hPa

Applicable grid (Other devices): 40 lp/cm  
(Grid is subject to restrictions on the installation orientation.)

Reducing scattered radiation: Even when a grid is not attached to the detector, the reduction in contrast caused by scattered radiation can be improved by image processing. Adjust the power of scatter correction by selecting the Effect check box to enable this control on the Scatter Correction control screen of the CXDI Control Software.

Rated power supply: 22 to 24 V DC, 1.2 A

Dimensions and mass: Approx. 460 x 460 x 15.5 mm  
Approx. 3.5 kg (incl. battery pack)

## Battery Pack LB-4A

Type:	Lithium ion battery
Operation temperature range:	5°C to 35°C
Rated voltage:	11.1 V DC
Capacity:	Typ. 1660 mAh / Min. 1600 mAh
Cycle life:	Approx. 300 cycles (fully charged to fully discharged)
Dimensions and mass:	Approx. 93 x 162 x 7 mm (excl. projecting parts) Approx. 160 g

## Image-capture computer

CPU:	Intel CPU with 4 cores and 8 threads or more
OS:	Microsoft Windows 10 (X64) RAM: Minimum 16 GB HDD: Minimum 50 GB free space Microsoft Windows 11 (X64) RAM: Minimum 16 GB HDD: Minimum 100 GB free space
Video card:	When Intelligent NR for Dynamic Imaging function is used GPU with performance equivalent to or exceeding NVIDIA RTX A4000 When Intelligent NR for Dynamic Imaging function is not used GPU with performance equivalent to or exceeding NVIDIA RTX A400

### Communication interfaces:

#### Card reader

Connection interface	USB
Readable cards	JIS X6301 1998 compliant
Readable encoding	JIS-II
Complies with CISPR 32 or equivalent standards.	

#### Barcode reader

Connection interface	USB, Bluetooth® (Serial Port Profile)
Compatible encodings	Code39, Code93, Code128, JAN/EAN-8, JAN/EAN-13, Industrial 2 of 5, Interleaved 2 of 5, Matrix 2 of 5, MSI, NW-7, UPC-A, UPC-E, RSS, EAN-128, Plessey, PDF417
Complies with CISPR 32 or equivalent standards.	

#### IR data communication unit

Used outside the patient environment.	
Complies with CISPR 32 or equivalent standards.	

### Access point

Use a product that satisfies the following requirements:

- Supports IEEE 802.11a/b/g/n.
- Supports 100BASE-TX/1000BASE-T Ethernet network interface.
- Used outside the patient environment.
- Complies with CISPR 32 or equivalent standards.

## 6.2 Characteristics

### Spatial resolution properties

---

A typical MTF value at 2 cycle/mm, RQA5 is 0.38. The level of uncertainty associated with measurement is estimated as less than  $\pm 10\%$ . The typical MTF value is the average of the MTF values of multiple initial mass-production units.

### DQE

---

A typical DQE value at 2  $\mu\text{Gy}$  in 0 lp/mm, RQA5 is 0.67. The level of uncertainty associated with measurement is estimated less than  $\pm 10\%$ . The typical DQE value is the average of the DQE values of multiple initial mass-production units.

# 7 Regulatory information

## 7.1 Medical equipment classification

Type of protection against electrical shock

Degree of protection against electrical shock

Internally powered equipment  
Class I Equipment, with Multi Box

Type B Applied Parts : Detector (Portable type)

## 7.2 CE marking

This product complies with the following:

Regulation (EU) 2017/745

Directive 2011/65/EU

Directive 2014/53/EU

Directive 2014/30/EU

Directive 2014/35/EU

## 7.3 For European Union

### Notification of serious incident

Any serious incident (defined in Article 2(65) of the Regulation (EU) 2017/745) that has occurred in relation to the product should be reported to the manufacturer and the competent authority of the Member State in which the user and/or patient is established.

### Electronic instructions for use

Instructions for use are available on the website for viewing and download by customers.











- <https://global.canon/en/ifu/medcom/index.html>

For details, please contact your sales representative or local Canon dealer.

## 7.4 EMD (Electromagnetic Disturbances)

This product is suitable for use in all establishments other than domestic and those directly connected to the public low-voltage power supply network that supplies buildings used for domestic purposes.

## 7.5 Details of markings on the equipment

	Direct current
	Alternating current
	Type B applied part
	Consult instructions for use
	Non-ionized radiation
	Manufacturer
	Date of manufacture
	Serial number
	This mark indicates that this equipment must be collected separately under the Directive on Waste Electrical and Electronic Equipment (WEEE) in the European Union.
	This mark indicates medical device which complies with the Regulation (EU) 2017/745.
	UK Responsible Person

# 8 System components

Component products are available either individually or as part of a set.

## CXDI-RF Wireless B1

(Unit: pieces)

### Basic components

---

#### Flat panel detector: AF-B1

##### **Detector**

Sensor unit: AF-B4343W.....	1
Battery pack: LB-4A .....	2

#### Control Software

#### Multi Box: MB-01

Multi Box.....	1
Power cord .....	1

### Optional equipment

---

#### **Wiring cable: WC-01**

#### **Status indicator: SI-01**

#### **Battery Pack: LB-4A**

#### **Ready indicator: RI-3A**

Hook-and-loop fastener (fastener hooks, fastener loops) (One pair is already applied to the product) .....	3 pairs
---	---------

#### **Battery Charger: BC-01**

Battery charger.....	1
AC adapter .....	1
Power cord .....	1

#### **Battery Charger: BC-1A**

Battery charger.....	1
Power cord .....	1

**XIF expansion unit for radiography: IFU-MB01-XIF**

X-ray interface cable expansion unit  
XIF expansion board ..... 1  
XIF cable ..... 1  
Binding screws ..... 4

**Expansion unit for AF-B4343W: IFU-MB01**

Wiring cable expansion unit for AF-B4343W  
Expansion board for AF-B4343W ..... 1  
Wiring cable ..... 1  
Flat head screws ..... 2  
Binding screws ..... 4

**Expansion unit for the CXDI-710/702 series: IFU-MB01-S**

Wiring cable expansion unit for the 710/702 series  
Expansion board for the CXDI-710/702 series ..... 1  
Expansion wiring cable for the CXDI-710/702 series ..... 1  
Flat head screws ..... 2  
Binding screws ..... 4

**Additional Detector**

---

**CXDI-710C Wireless detector**

**CXDI-810C Wireless detector**

**CXDI-410C Wireless detector**

**CXDI-702C Wireless detector: AR-C3543W**

**CXDI-402C Wireless detector: AR-C4343W**

**CXDI-703C Wireless detector**

**CXDI-803C Wireless detector**

**CXDI-403C Wireless detector**

**CXDI-720C Wireless detector**

**CXDI-820C Wireless detector**

**CXDI-420C Wireless detector**

**CXDI-420C Fixed detector**

## Optional function of software

**Scatter Correction for CXDI Series<sup>\*1</sup>**

---

**Advanced Edge Enhancement<sup>\*2</sup>**

---

**Free Rotation for CXDI Series<sup>\*3</sup>**

---

**CXDI Tomosynthesis Function<sup>\*4</sup>**

---

**CXDI DSA Function<sup>\*5</sup>**

---

**Built-in AEC Assistance<sup>\*6</sup>**

---

**Intelligent NR for Dynamic Imaging<sup>\*7</sup>**

---

\*1 Improve the reduction in contrast caused by scattered radiation.

\*2 Enhance the display of catheters, bony parts, such foreign matter as gauze, etc., in a captured image.

\*3 Images can be rotated one degree at a time.

\*4 Reconstruct the tomograms from the digital-cine images.

\*5 To conduct DSA (Digital Subtraction Angiography).

\*6 Enables operators to specify a pixel value and have a notification automatically sent to the X-ray generator when that value is reached. This function is not intended to provide AEC function by itself. Implementation to X-ray imaging system by its manufacturer is necessary for achievement of AEC function.

\*7 Perform noise reduction for images using AI (artificial intelligence).

## 9 Service information

### Product lifetime

The estimated product lifetime may be up to seven years under appropriate regular inspection and maintenance.

### Regular inspection and maintenance

In order to ensure the safety of patients, operating personnel and third parties, and to maintain the performance and reliability of the equipment, be sure to perform regular inspection at least once a year.

### Replacement parts support

Performance parts (parts required to maintain the functioning of the product) of this product will be stocked for 8 years after discontinuance of production, to allow for repair.

### Consumables

The following consumable can deteriorate because of its characteristics and structure. For purchase of consumables, contact your sales representative or local Canon dealer.

- Battery Pack LB-4A (Cycle life: Approx. 300 cycles)
- Battery cover (Replacement period: Approx. every 2 years)

### Technical Description

For the technical description, see the user's manual of the product.





\*BT8-2216-EN05\*



Manufacturer:  
**CANON INC.**

30-2, Shimomaruko 3-chome, Ohta-ku, Tokyo 146-8501, Japan  
Telephone: (81)-3-3758-2111

Revision Date: 2025-12

BT8-2216-EN05

1225P0.001

© CANON INC. 2024–2025