

# Ultra Short-throw Projectors

## <LV-WX300UST/LV-WX300USTi >

### ■ Outline of product

This new ultra short-throw projector belongs to a class of DLP portable projectors that can be used in a wide variety of scenarios including academic institutions.

The LV-WX300USTi features interactive function\*<sup>1</sup>, which is offered for the first time in the Canon projector lineup. This unique feature strongly supports both the education and business fields.

### ■ Product specifications

(Specifications and appearance may change without prior notice for reasons such as manufacturing and changes of components.)

|   |   |
|---|---|
| <b>Used power</b>                       | AC100 - 240 V 50Hz/60Hz   |
| <b>Consumed power</b>                   | Standard: 300W / Quiet: 240W (Lamp modes are Full Power and Power Saver.)<br>Standby (Network/RS232): 6.0W/0.5W   |
| <b>Picture element</b>                  | 0.65-type DMD device (aspect ratio 16: 10)<br>1280 dots x 800 dots, WXGA  |
| <b>Projection lens</b>                  | Installation distance range: 28.2 - 44.6 cm, 100-inch installation distance: 44.6 cm,<br>Zoom ratio: Fixed, Projection Ratio: 0.35 (a calculated value for 87-inch display)<br>Ultra-high pressure mercury lamp   |
| <b>Light source lamp</b>                | 230 W / 200 W (Lamp modes are Full Power and Power Saver.)  |
| <b>Output using light source</b>        | 80-inch to 100-inch (Image with the same aspect ratio as that of DMD)<br>Standard: 3000lm/Quiet: 2500lm (Lamp modes are Full Power and Power Saver.)  |
| <b>Projected image size</b>             | 80%   |
| <b>Light output*</b>                    | 7500: 1 (Auto Lamp control: ON, Image mode: Presentation, Lamp mode: Full Power)<br>UXGA to VGA   |
| <b>Peripheral contrast*</b>             | See List of supported signals   |
| <b>Contrast ratio*</b>                  | 75%, fixed  |
| <b>Input signal resolution</b>          | V ±40°  |
| <b>Corresponding scanning frequency</b> |   |
| <b>Lens shift</b>                       | Analog PC input: UXGA/SXGA+ / WXGA/SXGA/XGA/SVGA/VGA/MAC  |
| <b>Keystone correction range</b>        | Digital PC input: UXGA/SXGA+ / WXGA/SXGA/XGA/SVGA/VGA   |
| <b>Video signal</b>                     | HDMI input: 1080p/1080i/720p/576p/480p<br>Component video input: 1080p/1080i/720p/576p/576i/480p/480i<br>Video input (Composite, S-Video): NTSC/PAL/SECAM/NTSC4.43/PAL-M/PAL-N/PAL-60<br>Mini D-sub 15 x 2: Analog PC/Component video input<br>HDMI x 2: Digital PC/Digital video input<br>Mini DIN4: S-video input   |
| <b>Connection terminal</b>              | RCA: Video input<br>2RCA: Audio input<br>Mini jack x 2: Audio input x 1, Audio output x 1<br>Dsub9: RS-232 connection<br>RJ-45: Network connection (100BASE-TX / 10BASE-T)<br>USB type B: USB connection (USB2.0 compatible)<br><LV-WX300USTi><br>USB type A: USB connection (USB2.0 compatible) for interactive function<br>USB mini B: USB connection (USB2.0 compatible) for optional module |
| <b>Adjustable feet</b>                  | Front: 1, Rear: 2 (Max. angle 2 °)  |
| <b>Built-in speaker</b>                 | 10 W x 2, Stereo  |
| <b>Noise level</b>                      | 33 dB / 29 dB (Lamp modes are Full Power and Power Saver.)  |
| <b>Cabinet</b>                          | Molded plastic  |
| <b>External dimensions</b>              | Width 287.5 x Height 122.6 x Depth 374.5 mm (excluding protrusions)<br><LV-WX300UST> Width 287.5 x Height 167.6 x Depth 374.5 mm (including protrusions)<br><LV-WX300USTi> Width 287.5 x Height 193.7 x Depth 374.5 mm (including protrusions)  |
| <b>Weight</b>                           | About 5 kg  |
| <b>Environmental conditions</b>         | Usage environment: 5 °C to 40 °C  |
| <b>Supplied remote control</b>          | Operation distance (for wireless): About 8m (receiver front ±30°)   |

\* This indicates the overall average value of the product at the time of shipping, and it is listed in accordance with pattern for data projectors JIS X 6911:2003. The measurement method and measurement conditions are based on the Annex.

Note: This is the average. It may vary for each product.

## ■ Key features

- **WXGA-3000 lm and contrast ratio of 2300:1**

This projector is a WXGA model capable of providing light output of 3,000 lumens, which is bright for a projector in portable class. Its contrast ratio is 2300:1 to project sharp images.

- **Ultra short-throw projector that enables close-in projection onto a screen or wall**

This projector is an ultra short-throw model that realizes projection ratio of 0.35:1.

In order to project a 100-inch image on the wall, distance from the screen to projector is only 45cm.

- **Two HDMI terminals**

The projector is equipped with 2 HDMI terminals to support input of high-resolution digital videos. Connect with devices such as Blu-ray disc player to project high-resolution videos.

- **Interactive functions (LV-WX300USTi)**

The projector is equipped interactive functions.

## ■ External dimensions diagram

(Unit: mm)

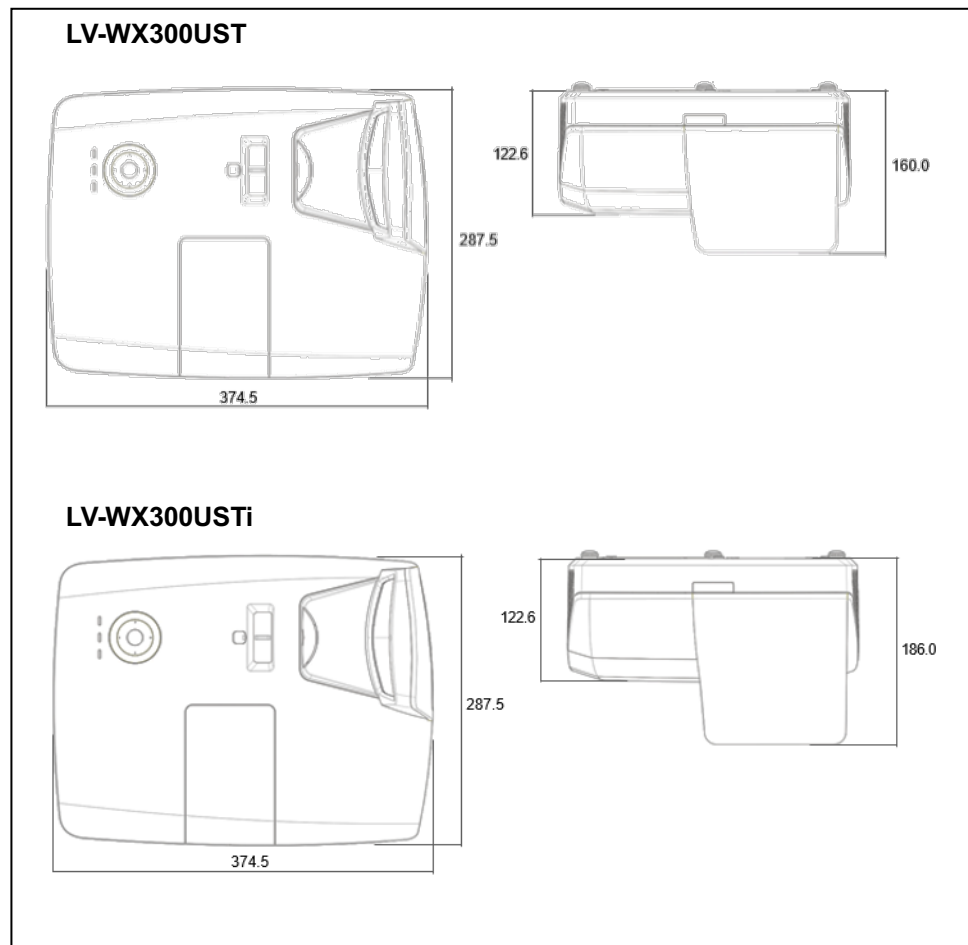

## ■ Terminals

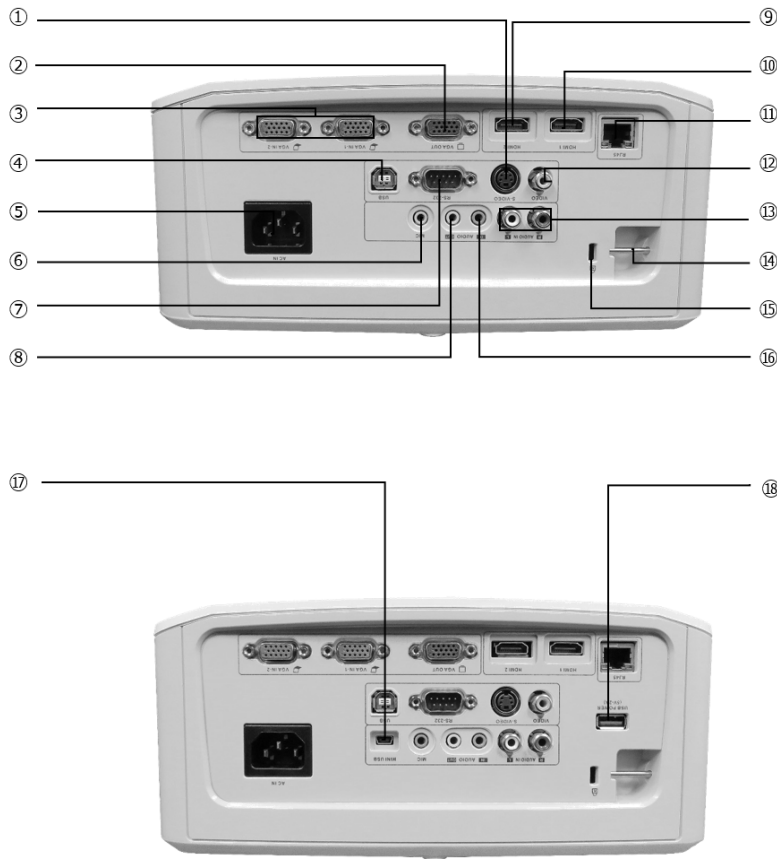

## [Common terminals]

- ① S-Video
- ② VGA out
- ③ VGA1, VGA2
- ④ USB
- ⑤ AC
- ⑥ Mic
- ⑦ RS-232
- ⑧ Audio out
- ⑨ HDMI 2
- ⑩ HDMI 1
- ⑪ RJ-45
- ⑫ Video
- ⑬ Audio L/R  
(for Video and S-Video)
- ⑭ Security bar
- ⑮ Kensington lock
- ⑯ Audio in

## [Only for the LV-WX300USTi]

- ⑰ Mini USB
- ⑱ USB power supply (5V-2A)

## ■ Names

LV-WX300UST

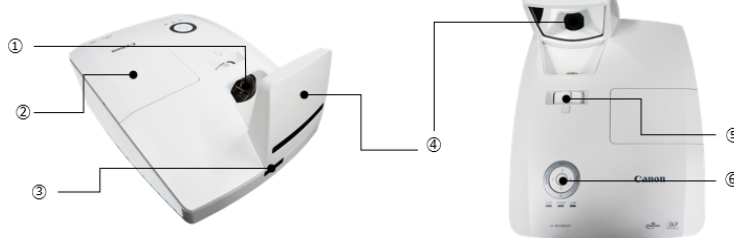

LV-WX300USTi

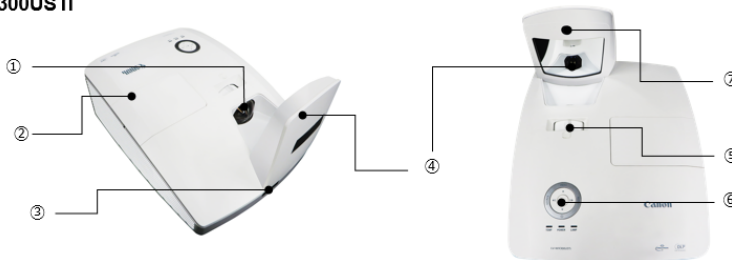

## [Common Names]

- ① Lens
- ② Lens cover
- ③ IR receiver
- ④ Aspheric mirror
- ⑤ Focus ring
- ⑥ Function keys

## [Only for the LV-WX300USTi]

- ① Camera

## ■ Installation distance and image size

Projection lens for this projector does not feature optical zoom function.  
For this reason, image size is adjusted by moving the installation position (throw distance).

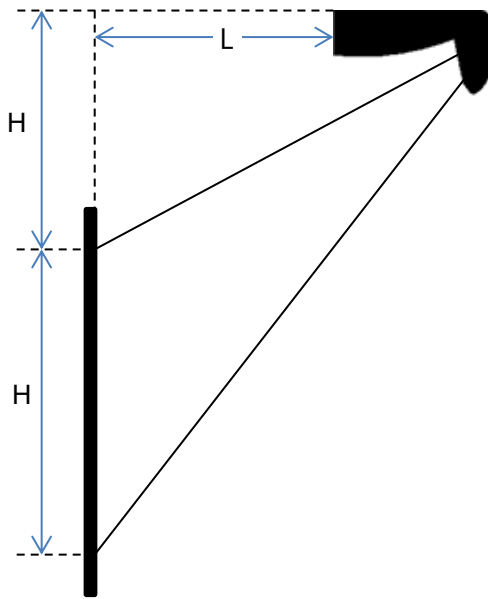

"L" in the diagram (left) represents throw distance. It is the horizontal distance from the front of the projector to the screen.

H represents the image height; it is the vertical distance from the top to the bottom of the image.

Hs is the distance in vertical direction from the bottom of the projector to the top of the image.

Ratio between H and Hs for this projector is fixed, as shown below:

$$\text{LV-WX300UST /LV-WX300USTi} \\ 10:2.5 \text{ (Hs} = \text{H} \times 0.25\text{)}$$

Although it is not shown in this diagram, the width of the image is indicated with W.

Note: Although this projector can be used in a conventional position (placed on a desktop), it is designed to be mounted on a wall up-side-down, using a bracket.

Optimum displayable image sizes are between 80 to 100 inches.  
Image size and throw distance are as indicated below.

(Unit: m)

| Image size (16:10) |        |        | Installation distance | Throw distance | Projection ratio |
|--------------------|--------|--------|-----------------------|----------------|------------------|
| Type               | W [cm] | H [cm] | L [cm]                | L' [cm]        | L'/W             |
| 80                 | 172    | 108    | 28.2                  | 60.2           | 0.350            |
| 85                 | 183    | 114    | 32.3                  | 64.3           | 0.351            |
| 90                 | 193    | 121    | 36.4                  | 68.4           | 0.353            |
| 95                 | 204    | 128    | 40.5                  | 72.5           | 0.354            |
| 100                | 215    | 135    | 44.6                  | 76.6           | 0.355            |

Note: Figures in the above chart are approximate.

This projector adopts aspheric mirror for its optical system. For this reason, there is a gap between installation distance and projection distance as shown in the diagram on the right. The difference is expressed with the following formula.

$$L' = L + 32.0$$

Projection ratio is calculated with the above formula using throw distance, not installation distance.

Projection ratio is not proportional to the throw distance because the image size at the starting point for throw distance is not zero.

This projector features 3 adjustable feet.

Feet are used to adjust left/right tilt.

The projection angle can be adjusted up to 2.0 degrees between the projector and installation surface.



## ■List of supported signals

The video signals that can be input in this product are described in the table below.

Video signal input is accepted in the following ranges: Horizontal scanning frequency between 15 KHz and 75 KHz, and vertical scanning frequency between 50Hz and 60Hz.

### ●Digital (DVI/HDMI) /Analog PC (RGB)

| Signal format | Horizontal frequency [KHz] | Vertical frequency [Hz] |
|---------------|----------------------------|-------------------------|
| 720x400       | 37.9                       | 85.04                   |
| 640x480       | 31.5                       | 60.0                    |
|               | 37.9                       | 72.8                    |
|               | 37.5                       | 75.0                    |
|               | 43.3                       | 85.0                    |
| 800x600       | 35.2                       | 56.3                    |
|               | 37.9*1                     | 60.3*1                  |
|               | 48.1                       | 72.2                    |
|               | 53.7                       | 72.2                    |
|               | 76.3*2                     | 120.0*2                 |
| 1024x576      | 35.8                       | 60.0                    |
| 1024x600      | 37.3                       | 60.0                    |
|               | 41.5                       | 65.0                    |
| 1024x768      | 48.4*1                     | 60.0*1                  |
|               | 56.5                       | 70.1                    |
|               | 60.0                       | 75.0                    |
|               | 68.7                       | 85.0                    |
|               | 97.6*2                     | 120.0*2                 |
|               | 99.0                       | 120.0                   |
| 1152x864      | 67.5                       | 75.0                    |
| 1280x720*1    | 45.0                       | 60.0                    |
|               | 90.0                       | 120.0                   |
| 1280x768      | 47.4                       | 60.0                    |
|               | 47.8*1                     | 59.9*1                  |
| 1280x800      | 49.7*1                     | 59.8*1                  |
|               | 62.8                       | 74.9                    |
|               | 71.6                       | 84.9                    |
|               | 101.6*2                    | 119.9*2                 |
| 1280x1024     | 64.0*3                     | 60.0*3                  |
|               | 80.0                       | 75.0                    |
|               | 91.1                       | 85.0                    |
| 1280x960      | 60.0*3                     | 60.0*3                  |
|               | 85.9                       | 85.0                    |
| 1280x1470     | -                          | 60.0                    |
| 1366x768*3    | 47.7                       | 60.0                    |
| 1400x1050*3   | 65.3                       | 60.0                    |
| 1440x900      | 55.5                       | 59.9                    |
|               | 55.9*3                     | 59.9                    |
|               | 70.6                       | 75.0                    |
| 1600x1200     | 75.0                       | 60.0                    |
| 1680x1050     | 64.7                       | 59.9                    |
|               | 65.3                       | 60.0                    |
| 1920x1200     | 74.0                       | 60.0                    |
| 1920x1080     | 67.5                       | 60.0                    |
| 1920x2205*4   | -                          | 23.97                   |

### ●Apple Macintosh (analog/digital)

| Signal format | Horizontal frequency [KHz] | Vertical frequency [Hz] |
|---------------|----------------------------|-------------------------|
| 640x480       | 35.0                       | 66.7                    |
| 832x624       | 49.7                       | 74.5                    |
| 1024x768      | 60.2                       | 74.9                    |
| 1152x870      | 68.7                       | 75.1                    |

### ●Digital video /Component video

| Signal format | Horizontal frequency [KHz] | Vertical frequency [Hz] |
|---------------|----------------------------|-------------------------|
| 480i          | 15.734                     | 60.0                    |
| 480p          | 31.5                       | 60.0                    |
| 576i          | 15.625                     | 50.0                    |
| 576p          | 31.3                       | 50.0                    |
| 720p          | 37.5                       | 50.0                    |
|               | 45.0                       | 60.0                    |
| 1080i         | 33.8                       | 60.0                    |
|               | 28.1                       | 50.0                    |
| 1080p         | 27.0                       | 24.0                    |
|               | 28.0                       | 25.0                    |
|               | 33.7                       | 30.0                    |
|               | 67.5                       | 60.0                    |
|               | 56.3                       | 50.0                    |

### ●Composite video

|           | Horizontal frequency [KHz] | Vertical frequency [Hz] |
|-----------|----------------------------|-------------------------|
| NTSC      | 15.734                     | 60.0                    |
| PAL/SECAM | 15.625                     | 50.0                    |

### <Notes on 3D>

\*1 Supports non-3D and 3D signal with Frame Sequential and Top-Bottom format.

\*2 Supports non-3D and 3D signal with Frame Sequential format

\*3 Supports non-3D and 3D signal with Top-Bottom format.

\*4 Supports 3D signal with Frame Packing format.

There 3D timing showing depend the EDID file and display card. It is possible that user cannot choose the above 3D timings on display card.

The resolution of the panel is 1280 x 800. Resolution other than native resolution may display with uneven size of text or lines.

## ■Accessories

|                                    |   |   |
|------------------------------------|---|---|
| Supplied<br>(common)               | Projector Remote Controller (with battery)<br>LV-RC10   | Power source: DC 3.0V (uses CR2025 battery)<br>Operating range: Distance of approx. 8m from the projector; angle of $\pm 30^\circ$ in any direction from directly in front of the infrared remote receiver. |
|                                    | Computer Cable  | Mini Dsub15-MiniDsub15<br>Used to connect the projector to a PC for transferring analog PC signals.   |
|                                    | AC Power Cord   | Connects the projector to the power plug  |
| Supplied (for the<br>LV-WX300USTi) | USB Cable   | Used with the projector's interactive functions   |
|                                    | Interactive Pen (with battery)  | Used with the projector's interactive functions   |
|                                    | CD-ROM  | Software to install on a PC for using the projector's interactive functions.  |
| Options                            | Projector Remote Controller (with battery)<br>LV-RC10<br>Projector Remote Controller (with battery)<br>LV-RC9 | Same as the supplied accessory.   |
|                                    | Wall-mounting Bracket LV-WL02   | Used to hang the projector from the wall  |
|                                    | Finger-Touch Module (for the LV-WX300USTi)  | Used for finger-touch writing using the projector's interactive functions.  |
| Replacement parts                  | Replacement Lamp  | Ultra high-pressure mercury lamp<br>Recommended replacement time*1:<br>5000H/8000H (Lamp mode: Full Power and Power Saver.)   |

\*1: When the lamp has a 50% survival rate and can maintain a 50% light retention ratio. This figure does not guarantee the lamp life.

## ■Precautions when installing/using

High wattage lamps are used in the projector, and it becomes very hot. Take care as follows.

- ① This projector produces intense light from the projection lens. Do not stare directly into the lens, otherwise damage to eyes could result.
- ② Do not set anything on top of the projector. Also do not project with projectors stacked directly on top of each other.
- ③ Do not place any object in front of the lens while the projector is in use as focused light projected to an object for a prolonged time may result in a fire.
- ④ Do not block the intake and exhaust vents of the projector.  
Also, install the projector so that the intake and exhaust vents are not subjected directly to warm air and cold air of air conditioning.
- ⑤ The projector uses high-pressure mercury lamp for its light source, which may deteriorate or reduce luminance owing to the characteristics and extensive use of the mercury lamp. Prolonged usage may also lead to breakage of the lamp. In such instances, immediately replace the lamp to a new lamp. Contact a local dealer for service and replacement of the lamp; such maintenance should be conducted at a service center by a qualified personnel.
- ⑥ When operating the projector inserted in a box, ensure that the ambient temperature within the box during operation is within the range of  $0^\circ\text{C}$  to  $40^\circ\text{C}$ . Also, do not block the intake and exhaust vents. Even when the ambient temperature is  $40^\circ\text{C}$  or lower, the protection circuit of the projector may function and shut down the projector due to internal retention of the exhaust heat. Sufficiently consider the ambient temperature environment when installing the projector.
- ⑦ Set the Fan Control mode (High altitude mode) to ON when using the projector in high altitudes (1,500 meters or more above sea level) where the atmospheric pressure is low.
- ⑧ Do not paint or place a sticker over the cover of Interactive Camera Receiver.
- ⑨ Do not use an IR remote or IR microphone in the same room when using the Interactive Pen. This may cause the Interactive Pen to malfunction.
- ⑩ Interactive Pen is not waterproof. Do not hold or use the pen with wet hands. Use the pen in a dry environment.
- ⑪ Interactive Pen can be used to draw by tracing gently over a projection surface. Do not press the pen hard against the surface.
- ⑫ Interactive Pen is a precision tool. Do not drop or give excessive force to the pen.
- ⑬ Interactive performance may decline when the Keystone function is operated.

20191227