

DLP Projector LX-MU800Z/LX-MU600Z



1. Main Features

1-1. WUXGA, 8000/6800 lm, laser light source installation models

These products are high-brightness and high-resolution DLP projectors.

Since the projector is equipped with a laser light source with a long life(*1) of 20,000 hours, it can maintain its brightness performance over a long period of time compared with products that use standard lamps.

This product can adjust the brightness about 20% to 25% of maximum output by adjusting laser power level .

*1: Life based on an average value of usage time when the brightness of the laser light source drops to approximately 50% of what it was at the time of starting to use the projector.

The time until the brightness actually drops to half varies by each unit and operating conditions.

1-2. Wide selection of interfaces

The projector is equipped with variety of input terminals including HDBaseT, 3G-SDI, HDMI, DVI-D, and 5BNC.

Since the projector can be simultaneously connected to multiple input devices, a highly usable system can be configured.

1-3. Geometry function which enables adjustment of various screen arrangements

The projector is equipped with the four functions of keystone correction, screen rotation adjustment, curved surface screen adjustment, and corner adjustment for performing digital image processing and optimal image display in accordance with the conditions on the screen.

1-4. Edge blend function which enables large screen projection using multiple projectors

The projector is equipped with a function that optimally processes the brightness at the edges of an image frame in order to link images of multiple projectors.

Since the projector can process all sides including top/bottom and left/right, an image can be theoretically linked for any number of projectors.

The large-screen image made of multiple times higher number of pixels of WUXGA makes a powerful impact on the viewers.

1-5. 7 types of projection lenses

The projector is equipped with a function that optimally processes the brightness at the edges of an image frame in order to link images of multiple projectors.

Since the projector can process all sides including top/bottom and left/right, an image can be theoretically linked for any number of projectors.

The large-screen image made of multiple times higher number of pixels of WUXGA will make a powerful impact on the viewers.

2. Specifications

2-1. Basic specifications

Model		LX-MU800Z	LX-MU600Z
Type	Product type	Projector	
	Imaging device, number	DMD x1	
DMD	Number of pixels	1920x1200 (WUXGA)	
	Size, Aspect ratio	0.67type、 16:10	
Light source	Type	Blue laser diode, yellow phosphor	
Images	Optical system	Time division four color display	
	Brightness (*1) (*2)	8000 lm	6800 lm
	Marginal illumination ratio (*1)	90%	
	Contrast ratio (*1)	1050:1/10500:1 (Dynamic Black Off/On)	
	Image size (*1)	50 – 300 inch (16:10)	
	Amount of lens shift (*1)	V: 0% – 50%, H: ±10% (Powered)	
	Electrical zoom (by length)	No	
	Keystone correction range(*1)	V ±40° H ±60°	
Terminals	Dsub15 (COMPUTER-1)	Analog PC / Component video input	
	5BNC (COMPUTER-2)	Analog PC / Component video input	
	DVI-D	Digital PC / Digital video input	
	HDMI	Digital PC / Digital video input	
	BNC (3G-SDI IN)	3G-SDI (Digital video) input	
	RJ-45	HDBaseT input / Network connection (100BASE-TX / 10BASE-T)	
	Dsub15 (MONITOR-OUT)	Image output	
	BNC (3G-SDI OUT)	3G-SDI (Digital video) output	
	Dsub9 (CONTROL)	RS-232 connection	
	Mini jack (TRIGGER)	For picture control	
	Mini jack (REMOTE)	Wired remote control connection	
	Image signal	Analog PC input	WUXGA/WSXGA+/UXGA/SXGA+/WXGA+/WXGA/SXGA/XGA/SVGA/VGA
Digital PC input		WUXGA/WSXGA+/UXGA/SXGA+/WXGA+/WXGA/SXGA/XGA/SVGA/VGA	
Digital video input		1080p/1080i/720p/576p/480p	
Component video input		1080p/1080i/720p/576p/480p/576i/480i	
HDBaseT		Same as Digital PC input/ digital video input	
Mechanics	Adjustable feet	Front: 2, Rear:2	
	Built-in speaker	No	
	Dimension	W: 500 mm, H: 216 mm, D: 594 mm	
	Weight	28.0 kg	
	Noise level (*2)	40/37 dB	
Others	Power supply	AC 100-240V, 50/60Hz	
	Maximum power consumption	890/845 W (100/240 V)	725/695 W (100/240 V)
	Standby power consumption (*3)	6.0/0.5 W	
	Operation environment	5 40	

*1: When using a Standard Zoom Lens (LX-IL03ST)

*2: Power mode of LASER is Normal/Eco (6-3 LASER > Power mode)

*3: Standby power is ON/OFF (6-5 CONTROL > Network > Standby Power)

2-2. Specification of projection lens (Option)

Projection lens	F number	Focal length	Zoom ratio	Image size	Throw ratio (*1)	Lens shift
LX-IL01UW	1.96-2.3	11.3-14.1 mm	1.25x	40-500 inch (*2)	0.75-0.93:1	V 0 - 50% H ±6.7%
LX-IL02WZ	1.85-2.5	18.7-26.5 mm	1.41x	40-500 inch (*2)	1.25-1.79:1	V 0 - 50% H ±10%
LX-IL03ST	1.7-1.9	26-34 mm	1.3x	40-500 inch (*2)	1.73-2.27:1	V 0 - 50% H ±10%
LX-IL04MZ	1.86-2.48	32.9-54.2 mm	1.65x	40-500 inch (*2)	2.22-3.67:1	V 0 - 50% H ±10%
LX-IL05LZ	1.85-2.41	52.8-79.1 mm	1.5x	40-500 inch (*2)	3.58-5.38:1	V 0 - 50% H ±10%
LX-IL06UL	1.85-2.48	78.5-121.9 mm	1.55x	40-500 inch (*2)	5.31-8.26:1	V 0 - 50% H ±10%
LX-IL07WF	1.85	11.6 mm	(Fixed)	40-500 inch (*2)	0.76:1	V 0% H 0%

*1: Calculated value for 80-inch image

*2: Indicates focus ability range in this chart. Optical feature guaranteed range is: 50-300 inches.

2-3. Installation Specifications

• Image Size and Projection distance

The product LX-MU800Z/LX-MU600Z is a projector with interchangeable lenses, and as of this writing (January 2016), 7 types of projection lenses are available.

Relationship between projection distance and picture is described below.

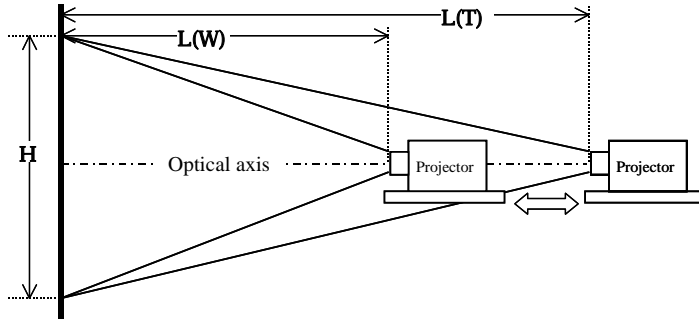

Picture of the height (H) is projected at between the shortest distance $L(W)$ and $L(T)$.

(W) denotes wide end, and (T) tele end.

The lens shift ratio can be changed on this projector.

The figure left denotes an example of 1:1 ratio, and the picture is divided into two making the optical axis as its center.

The figure indicates a case where a zoomable projection lens is used.

For a projection lens with no optical zoom feature, the projection distance is indicated by L.

The relationship between picture size and projection distance varies according to the projection lens mounted. The graph below denotes the projection distances for 100-inch image.

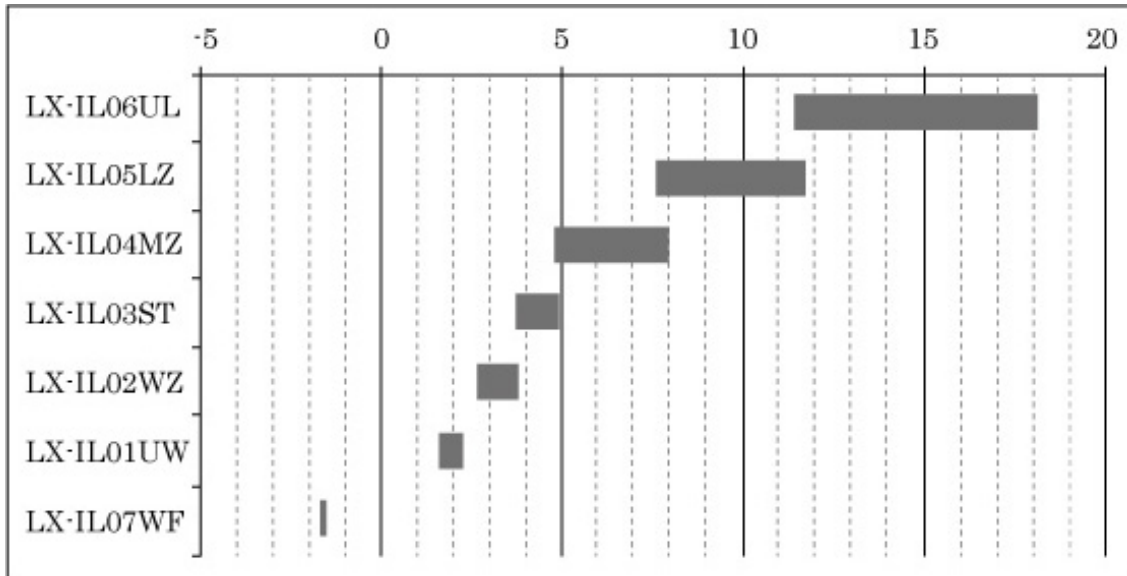

As seen above, projection lens is to be chosen according to the projection distance. Detailed projection distances are listed in the next page.

●Projection distance

Image size (16:10)			LX-IL01UW		LX-IL02WZ		LX-IL03ST		LX-IL04MZ	
Diagonal [type]	Width [cm]	Height [cm]	L(W) [m]	L(T) [m]	L(W) [m]	L(T) [m]	L(W) [m]	L(T) [m]	L(W) [m]	L(T) [m]
40	86	54	0.62	0.79	1.05	1.52	1.45	1.93	1.87	3.15
50	108	67	0.79	1	1.33	1.92	1.83	2.42	2.36	3.96
60	129	81	0.96	1.2	1.6	2.31	2.21	2.92	2.85	4.77
80	172	108	1.29	1.62	2.16	3.09	2.97	3.92	3.82	6.39
100	215	135	1.62	2.04	2.71	3.88	3.73	4.92	4.8	8
120	258	162	1.96	2.45	3.26	4.66	4.49	5.91	5.78	9.62
150	323	202	2.46	3.08	4.09	5.84	5.63	7.41	7.24	12.04
180	388	242	2.96	3.7	4.92	7.02	6.77	8.9	8.7	14.47
200	431	269	3.29	4.12	5.47	7.81	7.53	9.9	9.68	16.08
300	646	404	4.96	6.2	8.23	11.73	11.34	14.9	14.56	24.16
400	862	538	6.63	8.28	10.99	15.66	15.14	19.87	19.44	32.25
500	1077	673	8.3	10.36	13.75	19.59	18.94	24.85	24.32	40.33

Image size (16:10)			LX-IL05LZ		LX-IL06UL		LX-IL07WF
Diagonal [type]	Width [cm]	Height [cm]	L(W) [m]	L(T) [m]	L(W) [m]	L(T) [m]	L [m]
40	86	54	3.01	4.6	4.42	7.05	0.64
50	108	67	3.8	5.78	5.59	8.89	0.81
60	129	81	4.59	6.96	6.77	10.73	0.98
80	172	108	6.16	9.33	9.13	14.4	1.32
100	215	135	7.73	11.7	11.48	18.07	1.66
120	258	162	9.31	14.06	13.84	21.75	2.01
150	323	202	11.67	17.61	17.37	27.26	2.52
180	388	242	14.03	21.16	20.91	32.77	3.03
200	431	269	15.6	23.53	23.26	36.44	3.37
300	646	404	23.47	35.36	35.04	54.81	5.08
400	862	538	31.34	47.19	46.82	73.18	6.79
500	1077	673	39.21	59.02	58.6	91.54	8.5

* The distances listed on the table have been rounded off and are therefore approximate values.

* Indicates projection ability range in this chart. Optical feature guaranteed range is: 50-300 inches.

2-4. Adjustable foot

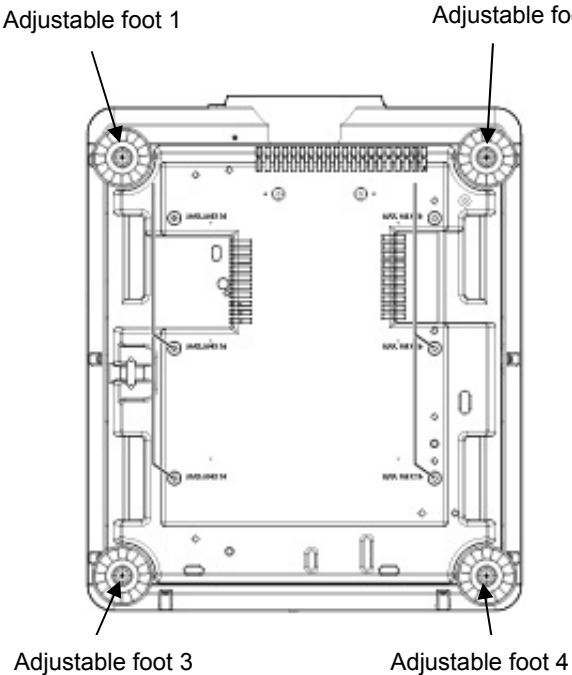
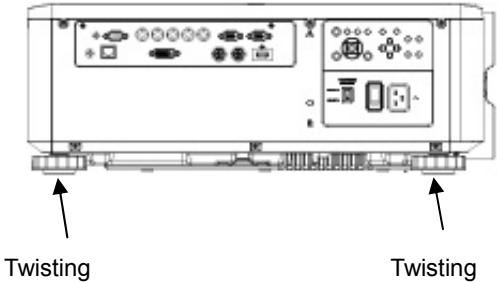
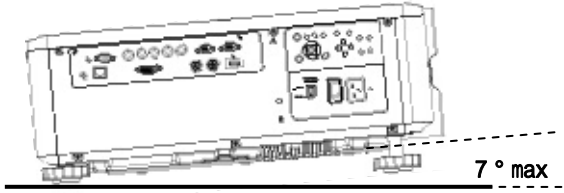
 <p>Adjustable foot 1</p> <p>Adjustable foot 2</p> <p>Adjustable foot 3</p> <p>Adjustable foot 4</p>	<p>The figure on the left is a schematic diagram of the bottom of the projector.</p> <p>As shown in the figure, there are four adjustable feet.</p> <p>Adjusting the lengths of Adjustable feet 1 and 2 raises the projection direction while adjusting the length of Adjustable feet 3 and 4 lowers the projection direction.</p> <p>Each adjustable foot can be used to make fine adjustments to the horizontal slant of the projector.</p>
 <p>Twisting</p> <p>Twisting</p>	<p>The figure on the left is a schematic diagram of the side of the projector.</p> <p>All adjustable feet are a screw-type and their heights can be adjusted by twisting.</p>
 <p>7 ° max</p>	<p>The projector can be set up at an angle of elevation of up to 7 degrees between itself and the surface it is placed on.</p>

* The figure is for explanation only and different from the actual product shape.

2-5. Supported image signal type

Signal Type	Resolution	Horizontal frequency (KHz)	Vertical frequency (Hz)	Clock frequency (MHz)	BNC - RGBHV	BNC - YUV	HD15- RGBHV	HD15- YUV	DVI-D	HDMI RGB	HDMI YUV	HDBaseT	3D FS Support
PC	640*480-60	31.47	59.93	25.175	V	-	V	-	V	V	-	V	V
	640*480-75	37.5	75	31.5	V	-	V	-	V	V	-	V	-
	640*480-85	43.27	85.01	36	V	-	V	-	V	V	-	V	-
	800*600-60	37.88	60.32	40	V	-	V	-	V	V	-	V	V
	800*600-75	46.88	75	49.5	V	-	V	-	V	V	-	V	-
	800*600-85	53.67	85.06	56.25	V	-	V	-	V	V	-	V	-
	848*480-60	31.02	60	33.75	V	-	V	-	V	V	-	V	V
	1024*768-60	48.36	60	65	V	-	V	-	V	V	-	V	V
	1024*768-75	60.02	75.03	78.75	V	-	V	-	V	V	-	V	-
	1024*768-85	68.88	85.03	94.5	V	-	V	-	V	V	-	V	-
	1280*720-60	44.69	59.91	74.37	V	-	V	-	V	V	-	V	V
	1280*768-60	47.8	59.87	79.5	V	-	V	-	V	V	-	V	V
	1280*800-60	49.702	59.81	83.5	V	-	V	-	V	V	-	V	V
	1280*960-60	60	60	108	V	-	V	-	V	V	-	V	V
	1280*1024-60	63.98	60.02	108	V	-	V	-	V	V	-	V	V
	1280*1024-75	79.98	75.02	135	V	-	V	-	V	V	-	V	-
	1280*1024-85	91.15	85.02	157.5	V	-	V	-	V	V	-	V	-
	1366*768-60	47.71	59.79	85.5	V	-	V	-	V	V	-	V	V
	1440*900-60	55.935	59.887	106.5	V	-	V	-	V	V	-	V	V
	1400X1050-60	65.517	59.98	121.75	V	-	V	-	V	V	-	V	V
1600*1200-60	75	60	162	V	-	V	-	V	V	-	V	V	
1680*1050-59.94	65.179	59.94	146	V	-	V	-	V	V	-	V	V	
1920*1200RB-60	74.04	59.95	154	V	-	V	-	V	V	-	V	V	
SDTV	1440x480i	15.73	60	27	-	-	-	-	-	V	V	V (HDMI)	
	1440x576i	15.62	50	27	-	-	-	-	-	V	V	V (HDMI)	-
	480i	15.734	59.94	13.5	-	V	-	V	-	-	-	-	-
	576i	15.625	50	13.5	-	V	-	V	-	-	-	-	-
EDTV	480p	31.47	59.94	27	V	V	V	V	V	V	V	V	-
	576p	31.25	50	27	V	V	V	V	V	V	V	V	-
	1080i	28.13	50	74.25	-	V	-	V	V	V	V	V	-
	1080i	33.75	60	74.25	-	V	-	V	V	V	V	V	
	720p	37.5	50	74.25	V	V	V	V	V	V	V	V	V
	720p	45	60	74.25	V	V	V	V	V	V	V	V	V
	1080p	27	24	74.25	V	V	V	V	V	V	V	V	-
	1080p	28.13	25	74.25	V	V	V	V	V	V	V	V	-
	1080p	33.72	29.97	74.175	V	V	V	V	V	V	V	V	-
	1080p	33.75	30	74.25	V	V	V	V	V	V	V	V	-
	1080p	56.25	50	148.5	V	V	V	V	V	V	V	V	V
	1080p	67.5	60	148.5	V	V	V	V	V	V	V	V	V

3. Accessories

*Only the items relevant to using the product have been extracted from a list of items.

Main Supplied Accessories	Remote control LX-RC01	Power supply: DC 3.0V (AA Battery x 2, included) Communication range: approx.10 m within ± 30 degrees of the receiver
	Power Cord	Connects the unit to a power source.
	Computer cable	Mini Dsub15-Mini Dsub15 This is used for connection with computer. This transmits analog PC signals.
	Anti-theft screw for lens	M4 x 0.7 x 70 mm Used to prevent the mounted projection lens from easily being removed.
	Dust Cap	Prevents dust from entering the projector from the lens mount opening while no projection lens is mounted to the projector.
Optional Part	Remote control LX-RC01	Same as the supplied remote
	Ceiling Attachment (*1) RS-CL15	Used to suspend the projector from ceiling.
Projection lens	Ultra Short Zoom Lens LX-IL01UW	Zoom ratio : 1.25x Projection distance : 11.3-14.1 mm F number : 1.96-2.3
	Short Zoom Lens LX-IL02WZ	Zoom ratio : 1.41x Projection distance : 18.7-26.5 mm F number : 1.85-2.5
	Standard Zoom Lens LX-IL03ST	Zoom ratio : 1.3x Projection distance : 26-34 mm F number : 1.7-1.9
	Medium-range Zoom Lenz LX-IL04MZ	Zoom ratio : 1.65x Projection distance : 32.9-54.2 mm F number : 1.86-2.48
	Long Zoom Lens LX-IL05LZ	Zoom ratio : 1.5x Projection distance : 52.8-79.1 mm F number : 1.85-2.41
	Ultra Long Zoom Lens LX-IL06UL	Zoom ratio : 1.55x Projection distance : 78.5-121.9 mm F number 1.85-2.48
	Short Fixed Lens LX-IL07WF	Zoom ratio : (No optical zoom) Projection distance : 11.6 mm F number : 1.85

*1: Since the size and weight varies according to the projector, be sure to use the specified fittings.
Consult a professional for mounting position and installation.

4. Product Appearance

4-1. Outline Drawings

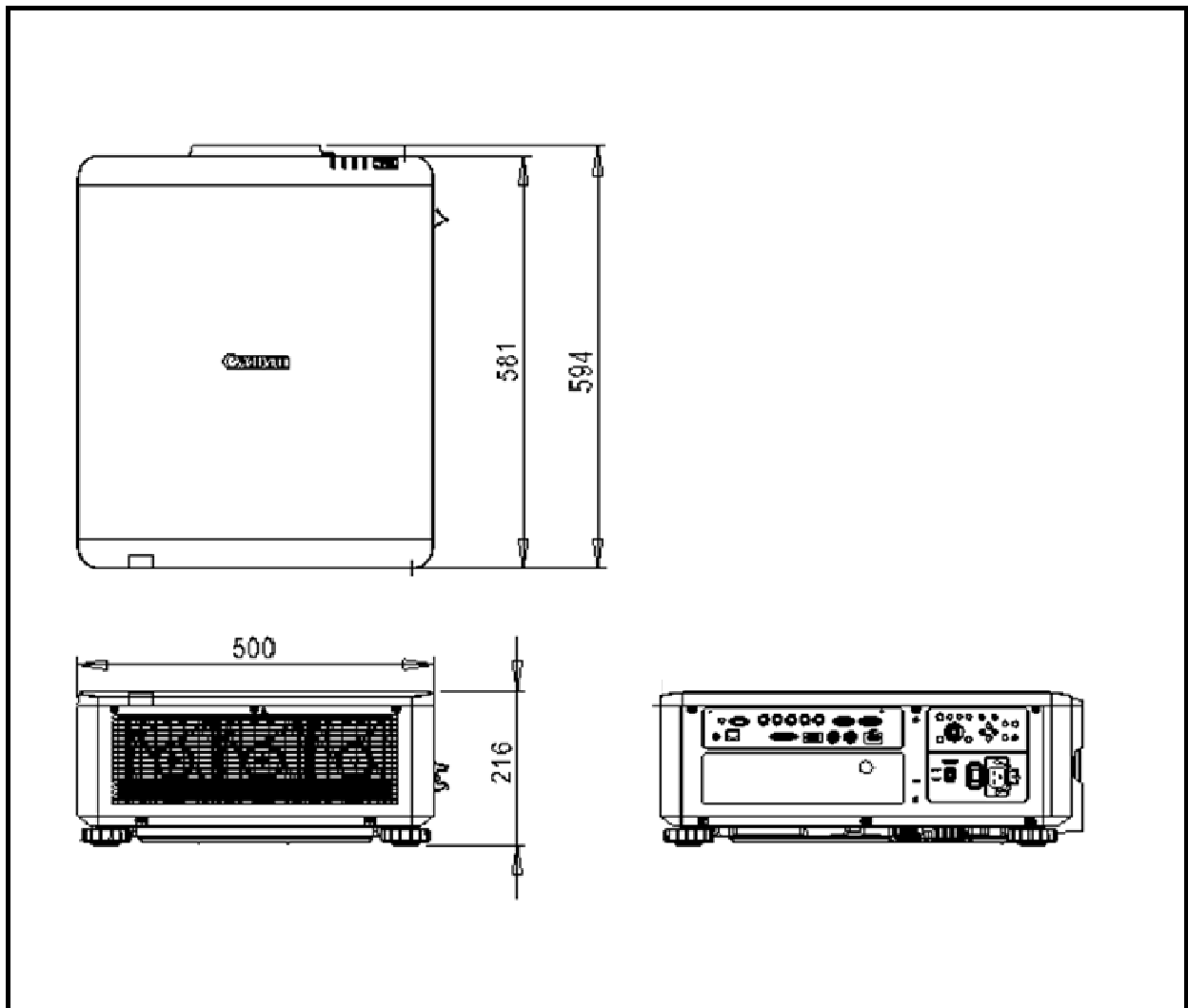

Dimensions	W: 500 mm, H: 216 mm, D: 594 mm (19.7 x 8.5 x 23.4 inch)
Mass	28.0 kg (61.7 lbs)

4-2. Part Names

Front View

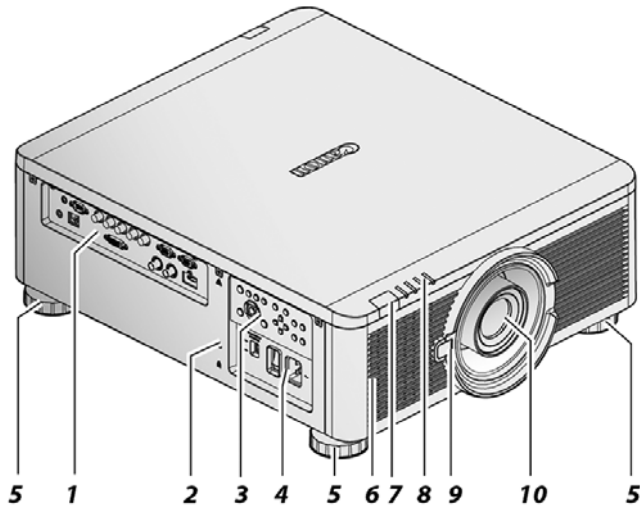

1. Terminals
2. Kensington Lock
3. Control Panel
4. Power Panel
5. Adjuster Foot
6. Air Intake Vent
7. Front IR Receiver
8. LED Indicators
9. Lens Release Button
10. Lens

Rear View

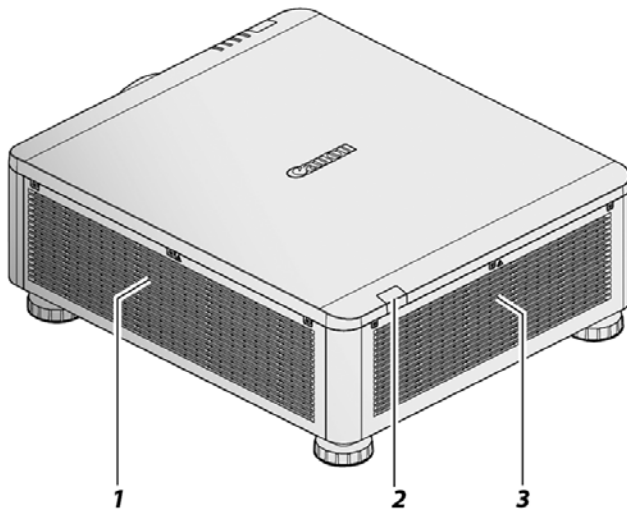

1. Air Intake Vent
2. Rear IR Receiver
3. Exhaust Vent

Bottom View

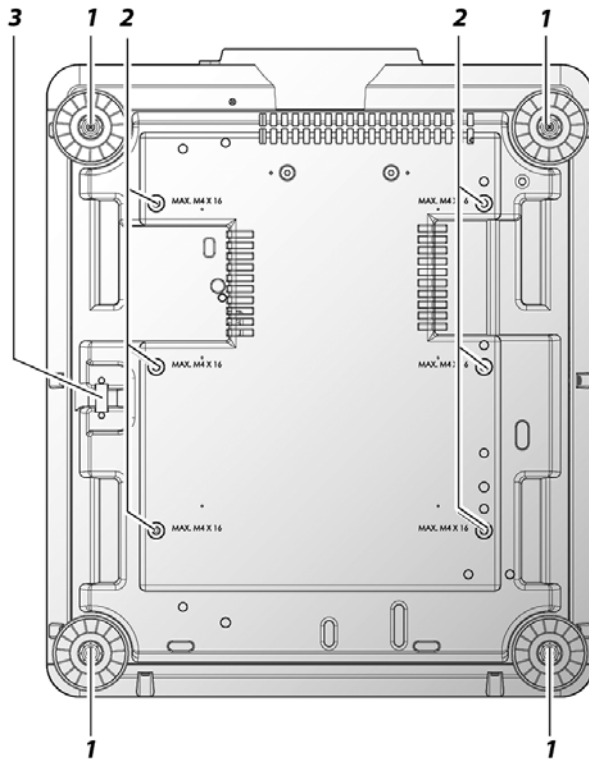

1. Adjusting Feet
2. Fixture screw holes
3. Security bar

4-3. Terminals

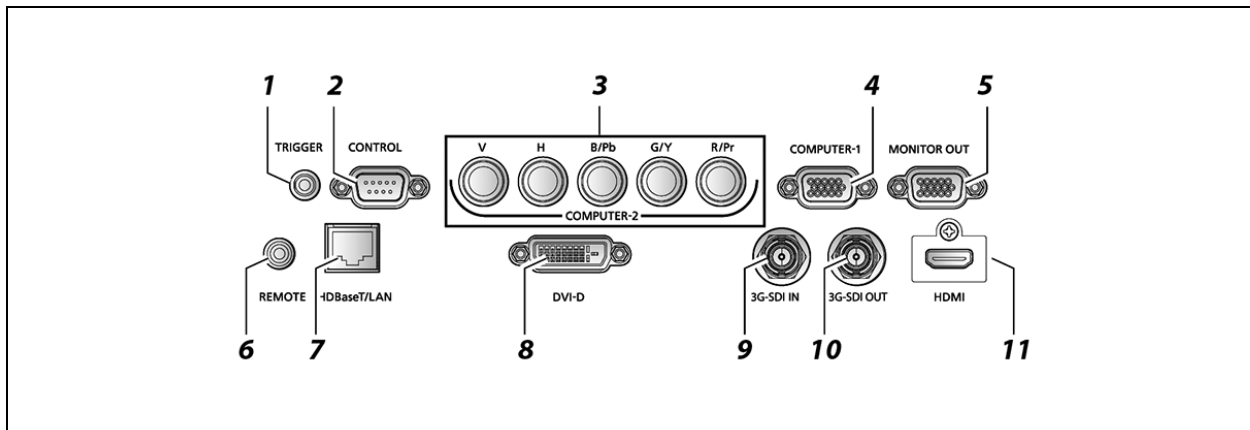

1. TRIGGER	12 V output (trigger for screen operation)
2. CONTROL	RS-232 connection (Service port)
3. COMPUTER-2	Analog PC / Componet video input
4. COMPUTER-1	Analog PC input
5. MONITOR-OUT	Analog PC output
6. REMOTE	Connect to a wired remote
7. HDBaseT/LAN	HDBaseT input / Network connection
8. DVI-D	Degital PC / Degital video input
9. 3G-SDI IN	SDI signal input
10. 3G-SDI OUT	SDI signal output
11. HDMI	HDMI input

4-4. Control area

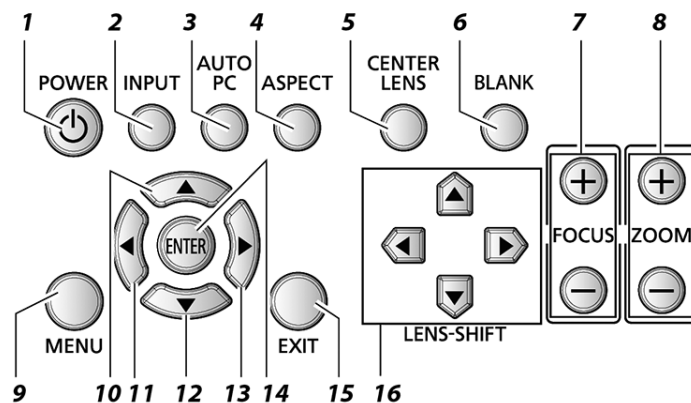

- | |
|------------------------------------------------------------------------------------------------|
| ① 【POWER】 button
Turns on and off the power. |
| ② 【INPUT】 button
Selects the input source. |
| ③ 【AUTO PC】 button
Automatically adjusts the projector to the optimal projection condition. |
| ④ 【ASPECT】 button
Changes the aspect ratio mode. |
| ⑤ 【CENTER LENS】 button
Sets the lens to the default center position. |
| ⑥ 【BLANK】 button
Turns on and off the laser light source. |
| ⑦ 【FOCUS】 button
Adjusts focusing. |
| ⑧ 【ZOOM】 button
Adjusts zooming. |
| ⑨ 【MENU】 button
Shows the menu screen. |
| ⑩ 【▲】 button
Moves the cursor up on the menu screen, etc. |
| ⑪ 【◀】 button
Moves the cursor left on the menu screen, etc. |
| ⑫ 【▼】 button
Moves the cursor down on the menu screen, etc. |
| ⑬ 【ENTER】 button
Sets an item you selected on the menu screen, etc. |
| ⑭ 【▶】 button
Moves the cursor right on the menu screen, etc. |
| ⑮ 【EXIT】 button
Cancels functions such as menu display and returns to the image display. |
| ⑯ 【LENS-SHIFT】 button
Moves the picture position, down, left, or right. |

5. Precautions For Use

- **Do not look directly into the projection lens while it is projecting.**

The projector emits concentrated strong light, which may damage your vision.

- **Do not place objects in front of the lens while projecting.**

Objects may heat up and burn if exposed to the concentrated light of the projector for long periods. Heated objects may melt and adhere to the projector.

- **Do not block the air vent while the projector is running.**

Allowing heat to build up inside the unit may lead to malfunctions or risk of fire.

- **When in household use, take countermeasures for electromagnetic interference when necessary.**

This product is not intended for household use (*1), and it may cause electromagnetic interference depending on how it is installed.

*1: VCCI Council, the Japanese body governing electromagnetic interference standards, defines the two sets of self-imposed regulations for the industry, namely "Class A Information Technology Equipment (ITE)" and "Class B Information Technology Equipment (ITE)".

Class B is the standard intended for household use whereas Class A is a relaxed standard than the former.

This product is a Class A ITE.

VCCI members indicate the standard compiled to the users in the method specified by VCCI Council.