

# LCOS Power Projector WUX6500

## ■ Outline of Product

This device is a 3-plate LCOS projector adopting the 0.71-type Liquid Crystal on Silicon (LCOS). The projector is equipped with a digital interface HDBaseT that enables transmission distance of up to 100 meters long, enabling integration of system equipment. In addition to video footage, the projection of video data up to WUXGA size (1920 dots x 1200 dots) is possible.

\*The "projection lens" for this product is sold separately.

## ■ Product specifications

(Specifications and appearance may change without prior notice for reasons such as manufacturing and changes of components.)

<b>Used power</b>	AC100 - 240 V 50Hz/60Hz
<b>Consumed power</b>	Lamp mode in Standard mode: 500W /in Eco mode: 410W (power of the Eco mode is calculated value therefore it is not guaranteed as specifications)
<b>Standby power</b>	2.0-0.3W (varies depending on the HDBaseT and network setting combination, see page 12)
<b>Picture element</b>	0.71-type LCOS panel (aspect ratio 16:10) Number of pixels: 2,304,000 pixels (1920 dots x 1200 dots, WUXGA)
<b>Projection lens</b>	(Separately sold) *A lens is not provided with this device. <Standard zoom lens (RS-IL01ST)> Lens configuration: 11 groups, 14 elements, F value: 1.89 - 2.65, Focus distance: 23.0 - 34.5mm, Projection distance range: 1.3 - 29m, 100-inch projection distance: 3.2 - 4.8m, Zoom ratio: 1.5 x (electric), Focus: electric <Telephoto zoom lens (RS-IL02LZ)> Lens configuration: 11 groups, 15 elements, F value: 1.99 - 2.83, Focus distance: 34.0 - 57.7mm, Projection distance range: 1.9 - 48.5m, 100-inch projection distance: 4.7 - 8.0m, Zoom ratio: 1.7 x (electric), Focus: electric <Fixed short focus lens (RS-IL03WF)> Lens configuration: 10 groups, 14 elements, F value: 2.0, Focus distance: 12.8mm, Projection distance range: 0.7 - 5.2m, 100-inch projection distance: 1.73m, Zoom ratio: 1.0 x (electric), Focus: electric In addition to the 3 aforementioned projection lenses, Canon offers Ultra telephoto zoom lens (RS-IL04UL), and Wide zoom lens (RS-IL05WZ). Please refer to the local Canon website for details specifications such as focus distance and projection distance range on the RS-IL04UL and RS-IL05WZ.
<b>Light source lamp</b>	340-NSHA lamp (Output Standard : 370W / Quiet: 300W)
<b>Projected image size</b>	40-type (0.86m x 0.54m) to 600-type (12.9m x 8.1m) (when an optional RS-IL01ST lens is used at 16:10 aspect ratio)
<b>Light output*</b>	Standard: 6500lm/Quiet: 5270lm (when an optional RS-IL01ST lens is used)
<b>Peripheral contrast*</b>	88% (when an optional RS-IL01ST lens is used)
<b>Contrast ratio*</b>	2000:1 (All white / All black; when an optional RS-IL01ST lens is used with lamp control function set to ON)
<b>Input signal resolution</b>	WUXGA to VGA
<b>Corresponding scanning frequency</b>	DVI input (digital PC): (H)31KHz~75KHz (V)50Hz~60Hz (dot clock) below 162MHz HDMI input (digital PC): (H)31KHz~75KHz (V)59Hz~60Hz (dot clock) below 162MHz HDMI input (digital video): (H)31.469KHz (V)59.940Hz [480p] (H)31.250KHz (V)50.000Hz [576p] (H)37.500KHz/45.000KHz (V)50.000Hz/60.000Hz [720p] (H)28.125KHz/33.750KHz (V)50.000Hz/60.000Hz [1080i] (H)56.250KHz/67.500KHz (V)50.000Hz/60.000Hz [1080p] Analog RGB input: (H)31KHz~75KHz (V)50Hz~60Hz (dot clock) below 162MHz Component video input: (H)15.734KHz (V)59.940Hz [480i] (H)31.469KHz (V)59.940Hz [480p] (H)15.625KHz (V)50.000Hz [576i] (H)31.250KHz (V)50.000Hz [576p] (H)37.500KHz/45.000KHz (V)50.000Hz/60.000Hz [720p] (H)28.125KHz/33.750KHz (V)50.000Hz/60.000Hz [1080i] (H)56.250KHz/67.500KHz (V)50.000Hz/60.000Hz [1080p]
<b>Lens shift</b>	Vertical -15% to 55%, horizontal -10% to 10% (when an optional RS-IL01ST lens is used)
<b>Lens position</b>	Position memory functions: Zoom, Focus, Lens shift, Keystone, Screen aspect, Screen color adjustment, Digital image shift
<b>Keystone correction range</b>	V ±20°, H ±20°(when an optional RS-IL01ST lens is used)
<b>Projection method</b>	Front ceiling / floor-mounted front / rear ceiling / floor-mounted rear
<b>Video signal</b>	Analog/digital PC input: WUXGA/UXGA/WSXGA+/SXGA+/WXGA+/FWXGA/WXGA/SXGA/XGA/SVGA/VGA Digital video input: 1080p/1080i/720p/576p/480p Component video input: 1080p/1080i/720p/576p/576i/480p/480i HDBaseT input: Same as Digital PC input and Digital Video input USB data transfer: JPEG still image Network connection: NMPJ image transmission (Canon proprietary protocol)
<b>Connection terminal</b>	DVI-I: Digital PC/analog PC input HDMI: Digital PC/Digital Video input (Deep color compatible) RJ-45 (HDBaseT): HDBaseT input (video, audio, control, network) Mini Dsub 15: Analog PC/component video input Mini jack x3: Audio in x2, video out x1, Mini jack x1: Wired remote connection Dsub9: RS-232C connection USB Type A: USB connection RJ-45: Network connection (1000BASE-T / 100BASE-TX / 10BASE-T)

\* This indicates the overall average value of the product at the time of shipping, and it is listed in accordance with pattern for data projectors JIS X 6911:2003. The measurement method and measurement conditions are based on the Annex.

<b>Cabinet</b>	Molded plastic
<b>External dimensions</b>	Width 380mm Height 170mm (including extrusions) Depth 430mm
<b>Weight</b>	About 8.5kg (excluding projection lens)
<b>Noise level</b>	Lamp mode in Standard mode: 43 dB/in Eco mode: 39 dB
<b>Environmental conditions</b>	Use environment: 0°C to 40°C Storage environment: -30°C to 60°C
<b>Supplied remote control</b>	Power supply used: DC 3V (2 AAA type batteries) Operation distance (for wireless): About 8m (receiver front ±25°), Supports 4 channels

Accessories ● Power cord ... 1 ● Computer connection cable (Mini Dsub 15-pin) ... 1\*1  
 ● Wireless remote connector (RS-RC04) ... 1 ● AAA size batteries ... 2  
 Sold separately ● Ceiling mounting brackets\*2 (RS-CL11) ● Ceiling pipe [400 - 600mm] (RS-CL08) ● Ceiling pipe [600 - 1000mm] (RS-CL09)  
 ● Top cover (RS-TC01) ● Remote controller (capable of connecting a wire\*3) (RS-RC05) ● Wireless remote controller (RS-RC04)  
 Replacement products ● Replacement-use lamp (RS-LP11) [Recommended replacement time\*4; 340W: 3000H/264W: 4000H]  
 ● Replacement air filter (RS-FL01)

\*1: Computer cable is not equipped in some models.

\*2: Always use the specified bracket. Consult a professional installer for location of installation and have the work done by technical experts.

\*3: Use third-party audio cable for connection (3.5 diagram stereo mini plug) \*4: When it has a 50% survival rate and can maintain a 50% light retention ratio.

## External dimensions diagram

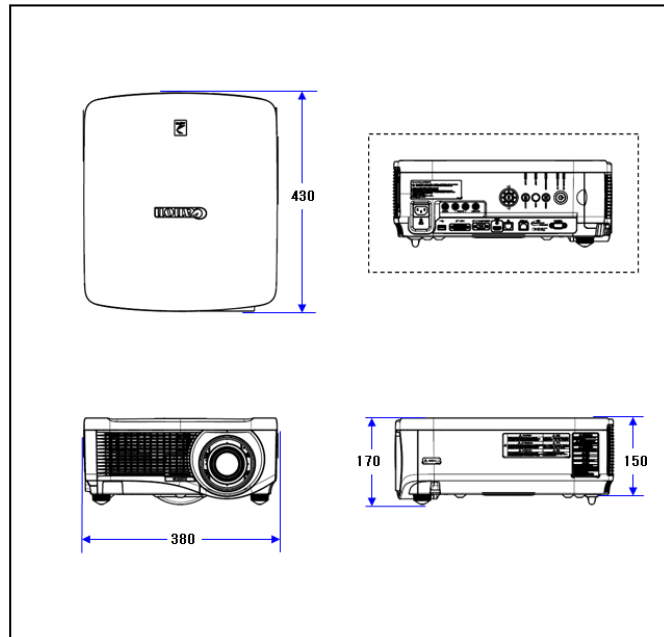

(Note) This diagram is not drawn to scale.

## <Side terminals>

(Unit: mm)

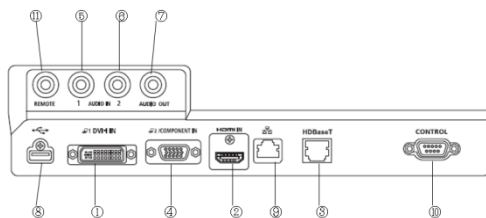

	Terminal		Signal
Video input	(1)	DVI-I	Digital PC/Analog PC1
	(2)	HDMI	HDMI (including audio input)
	(3)	RJ-45 (HDBaseT)	HDBaseT
	(4)	Mini Dsub 15-pin	Analog PC2/Component video
Audio output	(5)	Mini jack	Stereo audio
	(6)	Mini jack	Stereo audio
	(7)	Mini jack	Stereo audio
Control	(8)	USB type A	USB connection
	(9)	RJ-45	1000BASE-T/100BASE-TX/ 10BASE-T
	(10)	Dsub9	RS-232C connection
	(11)	RJ-45	Wired remote connection

## ■ Names

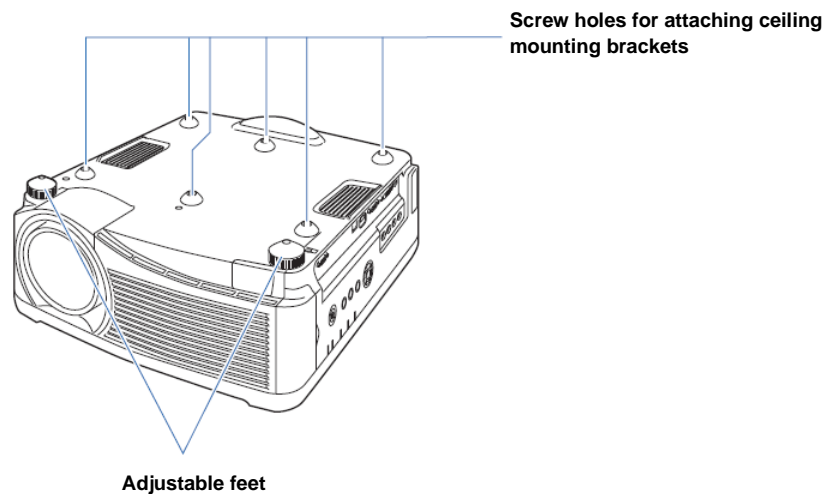
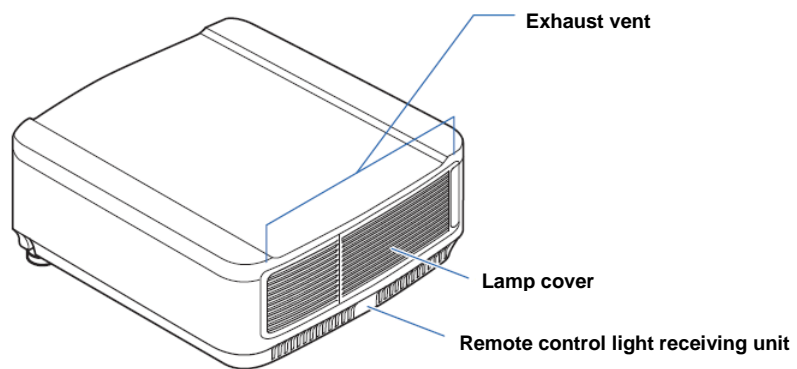
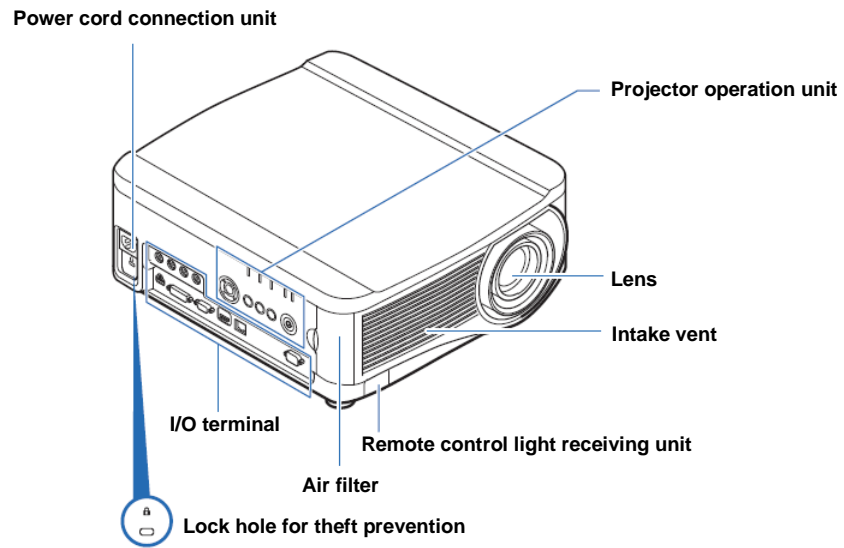

## ■ Projection-related dimensions

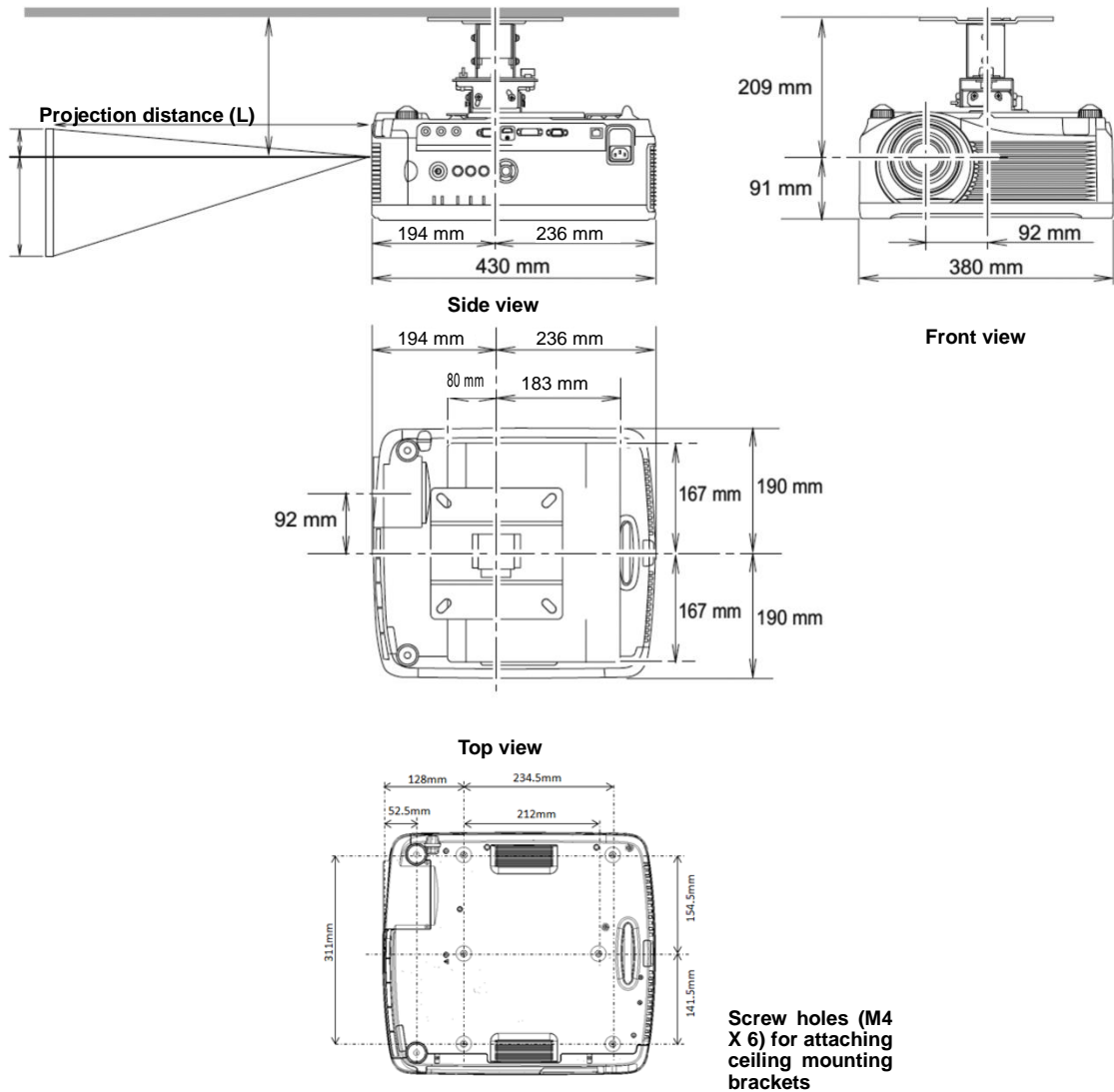

(Note) This diagram is not drawn to scale.

<Request>

- Have the work done by technical experts.
- When attaching to the ceiling, use the dedicated mounting brackets. Also, to prevent swaying or falling, stretch the wire supplied with the projector between the ceiling mounting brackets and ceiling.

## ■ Projection distance per interchangeable lens

(Unit: m)

Lens	100-type image	200-type image	300-type image	400-type image	500-type image	600-type image
RS-IL03WF	1.73	3.45	5.17			
RS-IL05WZ	2.2 - 3.2	4.3 - 6.5	6.5 - 9.7	8.6 - 13.0	10.8 - 16.3	12.9 - 19.5
RS-IL01ST	3.2 - 4.8	6.4 - 9.6	9.6 - 14.5	12.9 - 19.3	16.1 - 24.1	19.3 - 29.0
RS-IL02LZ	4.7 - 8.0	9.5 - 16.1	14.2 - 24.2	19.0 - 32.3	23.8 - 40.4	28.5 - 48.5
RS-IL04UL	7.6 - 14.9	15.2 - 29.8	22.7 - 44.6	30.2 - 59.4	37.7 - 74.2	45.2 - 89.0

## ■ Projection distance per projection lens

(Unit: m)

Image size (16:10)			Projection distance (L)[Screen to lens tip]				
Type	Width	Height	Standard zoom lens (RS-IL01ST)		Telephoto zoom lens (RS-IL02LZ)		Fixed short focus lens (RS-IL03WF)
			Wide lens	Tele lens	Wide lens	Tele lens	
40	0.9	0.5	1.3	2.0	1.9	3.3	0.69
45	1.0	0.6	1.4	2.2	2.1	3.6	
50	1.1	0.7	1.6	2.4	2.3	4.0	
55	1.2	0.7	1.8	2.6	2.6	4.4	
60	1.3	0.8	2.0	3.0	2.9	4.9	1.04
65	1.4	0.9	2.1	3.1	3.1	5.2	
70	1.5	0.9	2.2	3.4	3.3	5.6	
75	1.6	1.0	2.4	3.6	3.5	6.0	
80	1.7	1.1	2.6	4.0	3.9	6.6	1.38
85	1.8	1.1	2.7	4.1	4.0	6.8	
90	1.9	1.2	2.9	4.3	4.2	7.2	
95	2.0	1.3	3.0	4.6	4.5	7.6	
100	2.2	1.3	3.3	4.9	4.8	8.3	1.73
105	2.3	1.4	3.4	5.1	5.0	8.5	
110	2.4	1.5	3.5	5.3	5.2	8.9	
115	2.5	1.5	3.7	5.5	5.4	9.3	
120	2.6	1.6	4.0	5.9	5.8	9.9	2.07
125	2.7	1.7	4.0	6.0	5.9	10.1	
130	2.8	1.8	4.2	6.3	6.1	10.5	
130	2.9	1.8	4.3	6.5	6.4	10.9	
140	3.0	1.9	4.6	6.9	6.8	11.6	2.42
245	3.1	2.0	4.7	7.0	6.9	11.7	
150	3.2	2.0	4.8	7.2	7.1	12.1	
155	3.3	2.1	5.0	7.5	7.3	12.5	
160	3.4	2.2	5.3	7.9	7.8	13.2	2.76
165	3.6	2.2	5.3	8.0	7.8	13.3	
170	3.7	2.3	5.5	8.2	8.1	13.7	
175	3.8	2.4	5.6	8.4	8.3	14.1	
180	3.9	2.4	5.9	8.9	8.8	14.9	3.10
185	4.0	2.5	5.9	8.9	8.8	14.9	
190	4.1	2.6	6.1	9.2	9.0	15.3	
195	4.2	2.6	6.3	9.4	9.2	15.7	
200	4.3	2.7	6.6	9.9	9.7	16.6	3.45
205	4.4	2.8	6.6	9.9	9.7	16.5	
210	4.5	2.8	6.8	10.1	10.0	16.9	
215	4.6	2.9	6.9	10.4	10.2	17.4	
220	4.7	3.0	7.3	10.9	10.7	18.2	3.79
225	4.8	3.0	7.2	10.9	10.7	18.2	
230	5.0	3.1	7.4	11.1	10.9	18.6	
235	5.1	3.2	7.6	11.3	11.1	19.0	
240	5.2	3.2	7.9	11.9	11.7	19.9	4.14
245	5.3	3.3	7.9	11.8	11.6	19.8	
250	5.4	3.4	8.0	12.1	11.9	20.2	
255	5.5	3.4	8.2	12.3	12.1	20.6	
260	5.6	3.5	8.6	12.9	12.7	21.5	4.48
265	5.7	3.6	8.5	12.8	12.6	21.4	
270	5.8	3.6	8.7	13.0	12.8	21.8	
275	5.9	3.7	8.8	13.3	13.1	22.2	
280	6.0	3.8	9.2	13.9	13.6	23.2	4.83
285	6.1	3.8	9.2	13.8	13.5	23.0	
290	6.2	3.9	9.3	14.0	13.8	23.4	
295	6.4	4.0	9.5	14.2	14.0	23.8	
300	6.5	4.0	9.9	14.9	14.6	24.9	5.17

\* As for the value of L, a margin of error within  $\pm 5\%$  may be generated depending on the projection lens. The numbers in the table are rounded approximations.

(Unit: m)

Image size (16:10)			Projection distance (L)[Screen to lens tip]				Fixed short focus lens (RS-IL03WF)
Width	Height	Width	Standard zoom lens (RS-IL01ST)		Telephoto zoom lens (RS-IL02LZ)		
			Wide lens	Tele lens	Wide lens	Tele lens	
305	6.6	4.1	9.8	14.7	14.5	24.6	-
310	6.7	4.2	10.0	15.0	14.7	25.0	-
315	6.8	4.2	10.1	15.2	15.0	25.4	-
320	6.9	4.3	10.3	15.4	15.2	25.8	-
325	7.0	4.4	10.5	15.7	15.4	26.3	-
330	7.1	4.4	10.6	15.9	15.7	26.7	-
335	7.2	4.5	10.8	16.2	15.9	27.1	-
340	7.3	4.6	10.9	16.4	16.1	27.5	-
345	7.4	4.6	11.1	16.7	16.4	27.9	-
350	7.5	4.7	11.3	16.9	16.6	28.3	-
355	7.6	4.8	11.4	17.1	16.9	28.7	-
360	7.8	4.8	11.6	17.4	17.1	29.1	-
365	7.9	4.9	11.7	17.6	17.3	29.5	-
370	8.0	5.0	11.9	17.9	17.6	29.9	-
375	8.1	5.0	12.1	18.1	17.8	30.3	-
380	8.2	5.1	12.2	18.3	18.1	30.7	-
385	8.3	5.2	12.4	18.6	18.3	31.1	-
390	8.4	5.3	12.5	18.8	18.5	31.5	-
395	8.5	5.3	12.7	19.1	18.8	31.9	-
400	8.6	5.4	12.9	19.3	19.0	32.3	-
405	8.7	5.5	13.0	19.6	19.2	32.7	-
410	8.8	5.5	13.2	19.8	19.5	33.1	-
415	8.9	5.6	13.4	20.0	19.7	33.5	-
420	9.0	5.7	13.5	20.3	20.0	33.9	-
425	9.2	5.7	13.7	20.5	20.2	34.3	-
430	9.3	5.8	13.8	20.8	20.4	34.7	-
435	9.4	5.9	14.0	21.0	20.7	35.2	-
440	9.5	5.9	14.2	21.2	20.9	35.6	--
445	9.6	6.0	14.3	21.5	21.1	36.0	-
450	9.7	6.1	14.5	21.7	21.4	36.4	-
455	9.8	6.1	14.6	22.0	21.6	36.8	-
460	9.9	6.2	14.8	22.2	21.9	37.2	-
465	10.0	6.3	15.0	22.5	22.1	37.6	-
470	10.1	6.3	15.1	22.7	22.3	38.0	-
475	10.2	6.4	15.3	22.9	22.6	38.4	-
480	10.3	6.5	15.4	23.2	22.8	38.8	-
485	10.4	6.5	15.6	23.4	23.1	39.2	-
490	10.6	6.6	15.8	23.7	23.3	39.6	-
495	10.7	6.7	15.9	23.9	23.5	40.0	-
500	10.8	6.7	16.1	24.1	23.8	40.4	-
505	10.9	6.8	16.3	24.4	24.0	40.8	-
510	11.0	6.9	16.4	24.6	24.2	41.2	-
515	11.1	6.9	16.6	24.9	24.5	41.6	-
520	11.2	7.0	16.7	25.1	24.7	42.0	-
525	11.3	7.1	16.9	25.4	25.0	42.4	-
530	11.4	7.1	17.1	25.6	25.2	42.8	-
535	11.5	7.2	17.2	25.8	25.4	43.2	-
540	11.6	7.3	17.4	26.1	25.7	43.6	-
545	11.7	7.3	17.5	26.3	25.9	44.1	-
550	11.9	7.4	17.7	26.6	26.1	44.5	-
555	11.9	7.5	17.9	26.8	26.4	44.9	-
560	12.1	7.5	18.0	27.0	26.6	45.3	-
565	12.2	7.6	18.2	27.3	26.9	45.7	-
570	12.3	7.7	18.3	27.5	27.1	46.1	-
575	12.4	7.7	18.5	27.8	27.3	46.5	-
580	12.5	7.8	18.7	28.0	27.6	46.9	-
585	12.6	7.9	18.8	28.3	27.8	47.3	-
590	12.7	7.9	19.0	28.5	28.1	47.7	-
595	12.8	8.0	19.2	28.7	28.3	48.1	-
600	12.9	8.1	19.3	29.0	28.5	48.5	-

\* As for the value of L, a margin of error within  $\pm 5\%$  may be generated depending on the projection lens. The numbers in the table are rounded approximations.

## ■ Adjustable range of optical axis shift

A motorized lens shift function that can shift the image position vertically and horizontally is installed on this product. The lens shift specification per lens is as follows.

Lens shift	RS-IL01ST、RS-IL02LZ RS-IL04UL、RS-IL05WZ	RS-IL03WF
Volume	(V) -15%~55%, (H) -10%~10%	(V) -5%~5%, (H) -2%~2%
Ratio	(V) 3.5:6.5~10.5:0.5, (H) 6:4~4:6	(V) 4.5:5.5~5.5:4.5, (H) 5.2:4.8~4.8:5.2
Home position*1	(V) 50%/0%*2, (H) 0%	(V) 0%, (H) 0%

\*1: Position where the lens returns at reset. \*2: Selected from menu.

Variable range of the image with the combination of projection lens are shown below:

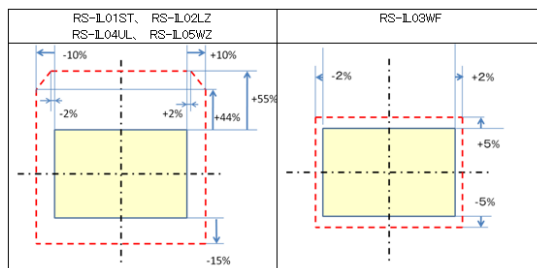

Image will move within the red dotted lines.

Center of the crossed line is the optical axis of the lens.

## ■ Installable angle



\* This product can be installed to allow for free rotation in all directions of 360 degrees as shown in the diagram.

Note: The lamp life may be shortened when the projector is positioned standing straight upward or downward. When using the projector in such positions, select a range of angles ( $\pm 45^\circ$  upward or downward) from the projector placement under Upright Projection menu. This selection of the settings changes the cooling fan operation.

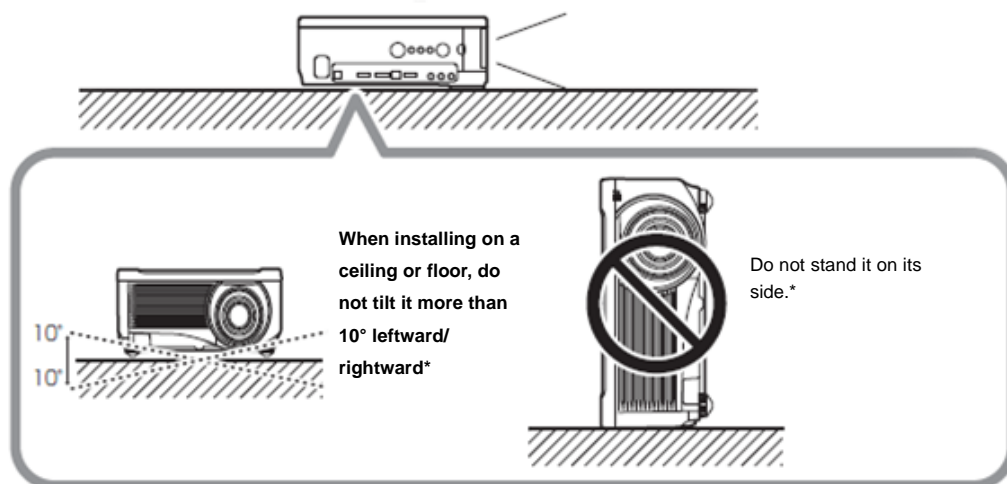

\* The lamp may become damaged.



## ■ Adjustable feet

The projector has two adjustable feet on the lens side of the bottom. Lift the adjustable feet on the lens side to adjust the angle of the projector.

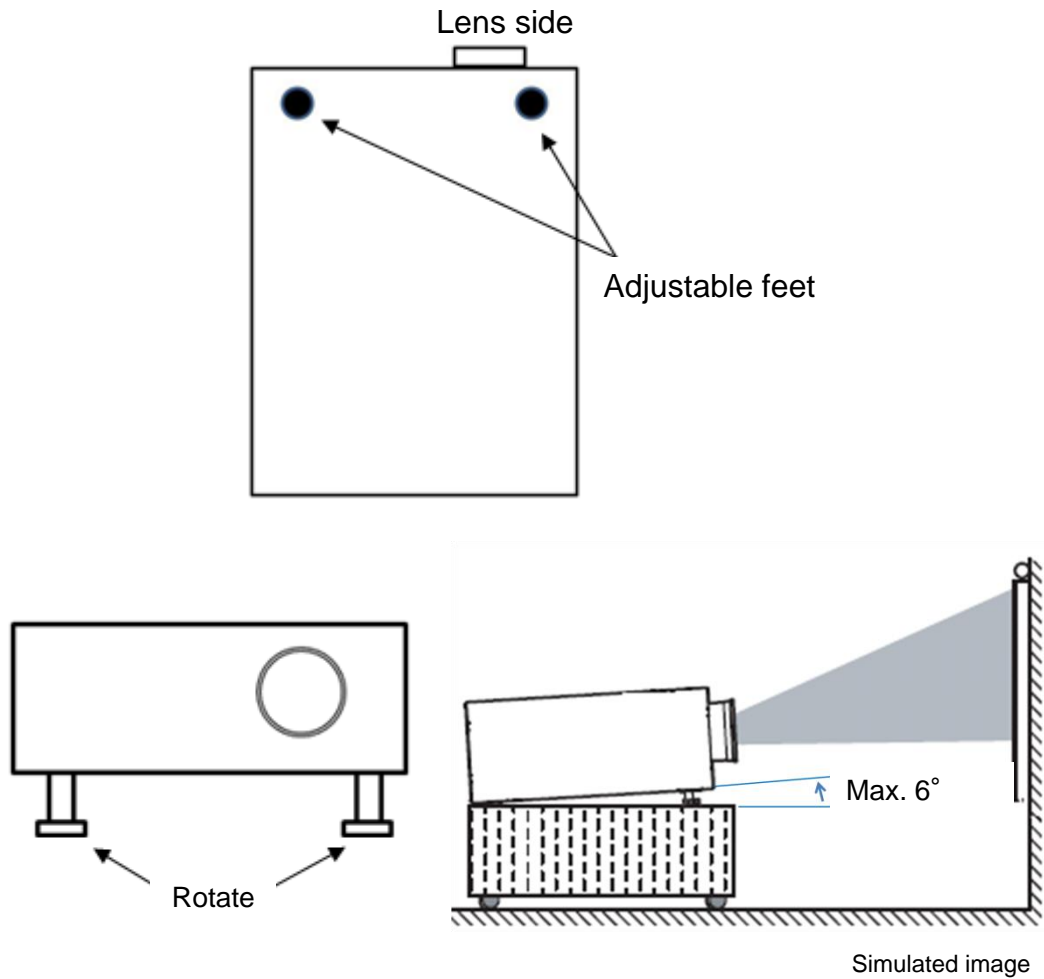

The angle of the projector is adjusted by rotating the adjustable feet. Angle can be set up to 6 degrees between the base and the projector.

## ■ List of supported signals

The video signals that can be input in this product are described in the tables below.

### ● DVI input (digital PC)

Signal format	Horizontal frequency [KHz]	Vertical frequency [Hz]	Dot clock [MHz]
640x480	31.469	59.940	25.175
720x480	31.469	59.940	27.000
720x576	31.250	50.000	27.000
800x600	37.879	60.317	40.000
1024x768	48.363	60.004	65.000
1280x720	37.500	50.000	74.250
	45.000	60.000	74.250
1280x800	49.702	59.810	83.500
	49.306	59.910	71.000
1280x1024	63.981	60.020	108.000
1366x768	47.712	59.790	85.500
1400x1050	64.744	59.948	101.000
	65.317	59.978	121.750
1440x900	55.935	59.887	106.500
	55.469	59.901	88.750
1600x900	60.000	60.000	108.000
1600x1200	75.000	60.000	162.000
1680x1050	64.674	59.883	119.000
	65.290	59.954	146.250
1920x1080	27.000	24.000	74.250
	56.250	50.000	148.500
	67.500	60.000	148.500
1920x1200	74.038	59.950	154.000
1920x1080 PsF	27.000	24.000	74.25
	28.125	25.000	74.25
	33.750	30.000	74.25

### ● HDMI input (digital PC, digital video)

Signal format	Horizontal frequency [KHz]	Vertical frequency [Hz]	Dot clock [MHz]
640x480	31.469	59.940	25.175
800x600	37.879	60.317	40.000
1024x768	48.363	60.004	65.000
1280x800	49.702	59.810	83.500
	49.306	59.910	71.000
1280x1024	63.981	60.020	108.000
1366x768	47.712	59.790	85.500
1400x1050	64.744	59.948	101.000
	65.317	59.978	121.750
1440x900	55.935	59.887	106.500
	55.469	59.901	88.750
1600x900	60.000	60.000	108.000
1600x1200	75.000	60.000	162.000
1680x1050	64.674	59.883	119.000
	65.290	59.954	146.250
1920x1200	74.038	59.950	154.000
480p	31.469	59.940	27.000
576p	31.250	50.000	27.000
720p	37.500	50.000	74.250
	45.000	60.000	74.250
1080i	28.125	50.000	74.250
	33.750	60.000	74.250
1080p	27.000	24.000	74.250
	56.250	50.000	148.500
	67.500	60.000	148.500

### ● HDBaseT input

Signals that are transmitted can be displayed in the same resolution and frequencies as the HDMI input as shown in the above chart.

- HDBaseT signals are signals specified by the HDBaseT standards.
- The signal is transmitted as HDBaseT signal through the cable and converted to HDMI signal when inputted to the projector.
- Proper display is not guaranteed when receiving HDBaseT signal that cannot be converted back to any of the HDMI signal listed above.

Notes: Always use STP cable that is above CAT5e specified by the TIA (Telecommunications Industry Association) of the United States. The length of 100 meters contains the length of patch cable and connectors. However, proper projection performance may not be achieved even within the specified distance, depending on the type of cable used and installation conditions.

● **Analog PC input (1, 2)**

Signal format	Horizontal frequency [KHz]	Vertical frequency [Hz]	Dot clock [MHz]
640x480	31.469	59.940	25.175
720x480	31.469	59.940	27.000
720x576	31.250	50.000	27.000
800x600	37.879	60.317	40.000
848x480	31.020	60.000	33.750
1024x768	48.363	60.004	65.000
1280x768	47.776	59.870	79.500
	47.396	59.995	68.250
1280x800	49.702	59.810	83.500
	49.306	59.910	71.000
1280x960	60.000	60.000	108.000
1280x1024	63.981	60.020	108.000
1366x768	47.712	59.790	85.500
1400x1050	64.744	59.948	101.000
	65.317	59.978	121.750
1440x900	55.935	59.887	106.500
	55.469	59.901	88.750
1600x900	60.000	60.000	108.000
1600x1200	75.000	60.000	162.000
1680x1050	64.674	59.883	119.000
	65.290	59.954	146.250
1920x1080	56.250	50.000	148.500
	67.500	60.000	148.500
1920x1200	74.038	59.950	154.000

● **Component video input**

Signal format	Horizontal frequency [KHz]	Vertical frequency [Hz]	Dot clock [MHz]
480i	15.734	59.940	13.500
480p	31.469	59.940	27.000
576i	15.625	50.000	13.500
576p	31.250	50.000	27.000
720p	37.500	50.000	74.250
	45.000	60.000	74.250
1080i	28.125	50.000	74.250
	33.750	60.000	74.250
1080p	56.250	50.000	148.500
	67.500	60.000	148.500
1080PsF	27.000	24.000	74.25
	28.125	25.000	74.25
	33.750	30.000	74.25

Analog/digital PC signals in this specification refer to RGB video signal. This is because signals that are outputted from PC in most cases are in that format.

Component video/digital video signals in this specification refer to color-difference signal because signals that are outputted from video equipment in most cases are in that format.

Please note that Composite video and S video signals are not included.

Specifications in above charts are subject to change without notice.

Notes: If the analog PC signal of the dot clock is greater than 162MHz, the images are not projected correctly. Use VGA cable with all pins connected. Images may not project properly if the correct VGA cable is not used.

● **USB video signal (only for still images)**

Images that are stored in a USB memory can be projected as still images by inserting the USB memory into the projector.

File type	JPEG
Format	Standard DCT method (Baseline)
Max. pixels	10912 x 8640

Only JPEG files can be read by the projector with maximum pixels of 10912 x 8640.

It also supports Standard DCT method (baseline) format. Optimized, progressive and reversible methods are not supported.

Note that when JPEG still image is inputted, digital zoom operation from display menu will not be supported.

Slideshow setting for video input via USB is done from the video setting menu; use USB file browser to display the video input via USB.

● **Network video input (only for still images)**

The projector will receive still images from a computer (when NMPJ in operation) via LAN network. Still images are output to the projector by converting the image to the number of pixels of the LCOS device used for the projector.

## ■ HDBaseT specifications

HDBaseT is used to transfer video signal and network data. HDBaseT transmitter equipment can be connected directly to the projector using a network cable as the projector is equipped with a receiver.

### ●For video signals (HDMI cable is used for connection ①)

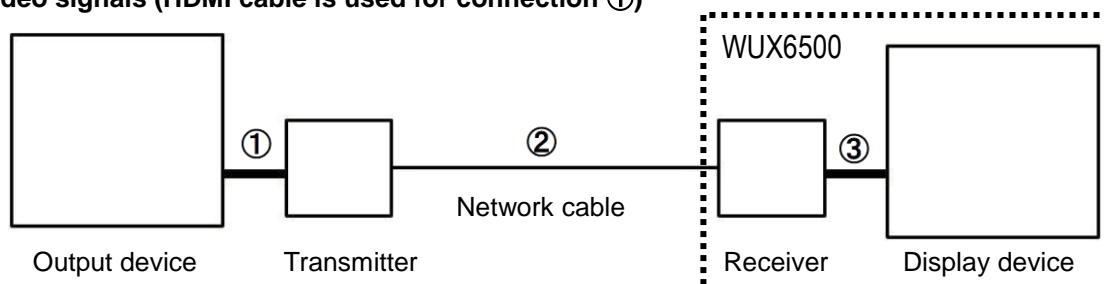

- ① Video signal is sent to the transmitter from an output device such as Blu-ray player.
- ② Transmitter then converts the video signal into HDBaseT signal and sends out.
- ③ Receiver receives the HDBaseT signal and converts to an HDMI signal and sends out.
- ④ Display device will display the HDMI signal.

### ●For network communications (Network cable is used for connection ①)

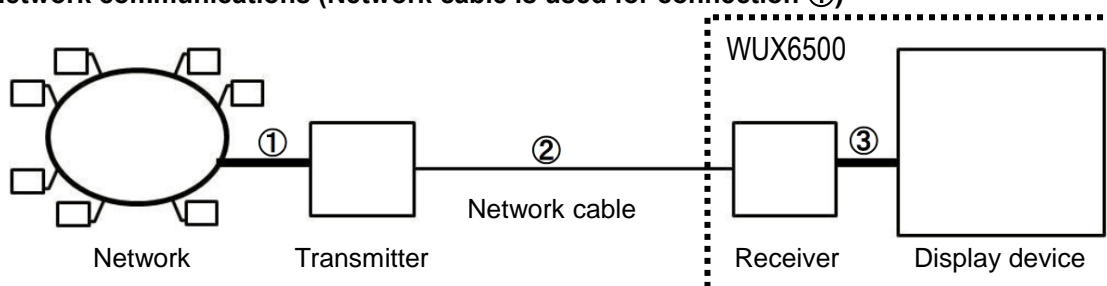

- ① Network data is sent to the transmitter from a secured network.
- ② Transmitter then converts the network data into HDBaseT signal and sends out.
- ③ Receiver receives the HDBaseT signal and converts to a network data and sends out.
- ④ Network data from a display device can transmit in the same manner in reverse direction.

List of HDBaseT transmitters (TX) confirmed to work with the WUX6500

Manufacturer	Model Name	Video	Audio	LAN	Serial
Crestron	DM-TX-201C	Yes	Yes	Yes	No
	DM-TX-401C	Yes	Yes	Yes	No
AMX	DX-TX	Yes	Yes	Yes	Yes
Kramer	TP-581T	Yes <sup>※1</sup>	Yes	Yes	Yes
	TP-582T	Yes	Yes	Yes	Yes
Extron <sup>※2</sup>	XTP T USW 103	No	No	No	No
Gefen	GEF-HDCAT5-ELRPOL	Yes	Yes	No <sup>※3</sup>	No
Atlona	AT-HDTX-RSNET	Yes <sup>※1</sup>	Yes	Yes	No
CYP	PU-507-KIT	Yes <sup>※1</sup>	Yes	Yes	Yes
IDK	HDC-TH100-C	Yes	Yes	Yes	No <sup>※4</sup>
IMAGENICS	CRO-DE20TX	Yes	Yes	No	No <sup>※4</sup>

※1 When a certain input device is connected, the picture may not be displayed in intended resolution.

※2 Extron XTP is not supported.

※3 LAN transmission disabled when the projector is in Standby mode (Tx is incompatible with LPPF2 mode)

※4 Serial transmission disabled when the projector is in Standby mode.

● **HDBaseT cable and transmission distance**

Theoretically HDBaseT is designed for data transmission of up to 100 meters in length however depending on the type of network and transmitter used, the said length may not be met. This is likely when signals with extensive data capacity are transferred. We recommend using shielded type cables (TIA-specified CAT6 or CAT7 cable).

● **Others regarding network transmission**

Transmission speed of 100BASE-T/10BASE-T is supported on the HDBaseT network. On the contrary, RJ-45 terminal exclusive for network use supports 1000BASE-T; thus the transmission speed is slower when compared to RJ-45 terminal. The advantage of HDBaseT is the capability to transfer video signal and network communication data simultaneously, which contributes to reducing the number of cables.

Standby power for the projector setup and network setup will change accordingly:

Interface setup		Network function	
HDBaseT	Selection of a wired network	On (Eco)	Off
ON	LAN port	2.0W	1.9W
ON	HDBaseT	2.0W	1.9W
OFF	LAN port	0.7W	0.3W

■ **NMPJ1.3**

Video data from the computer can be shared and distributed via network.

- The latest functions can be enjoyed with the Auto Update feature.
- Use DNS to search for a projector with its host name.
- Compatible with Windows 10

■ **List of supported signals**

The serial terminals conform to RS-232C. To control the projector with a PC, prepare communication software and input data based on the following communication conditions and basic format.

<Serial input terminals>

- Pin array

Pin number	Signal
1	OPEN
2	RxD
3	TxD
4	OPEN
5	GND
6	OPEN
7	OPEN
8	OPEN
9	OPEN

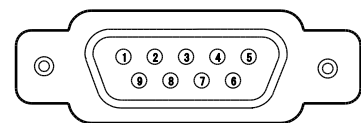

● **Communication format**

Communication method: RS-232-C asynchronous half-duplex communication  
 Communication speed: 19200bps  
 Character length: 8-bit  
 Stop bit: 2-bit  
 Parity: No  
 Flow control: No

• List of control commands

Command type		ASCII notation	Binary notation
Power supply	Power ON	POWER ON<CR>	50h 4Fh 57h 45h 52h 20h 4Fh 4Eh 0Dh
	Power OFF	POWER OFF<CR>	50h 4Fh 57h 45h 52h 20h 4Fh 46h 46h 0Dh
Power supply status acquisition		GET POWER<CR>	47h 45h 54h 20h 50h 4Fh 57h 45h 52h 0Dh
Input source	DigitalPC	INPUT=D-RGB<CR>	49h 4Eh 50h 55h 54h 3Dh 44h 2Dh 52h 47h 42h 0Dh
	DigitalVideo	INPUT=HDMI<CR>	49h 4Eh 50h 55h 54h 3Dh 48h 44h 4Dh 49h 0Dh
	AnalogPC	INPUT=A-RGB<CR>	49h 4Eh 50h 55h 54h 3Dh 41h 2Dh 52h 47h 42h 0Dh
	Component	INPUT=COMP<CR>	49h 4Eh 50h 55h 54h 3Dh 43h 4Fh 4Dh 50h 0Dh
Input source acquisition		GET INPUT<CR>	47h 45h 54h 20h 49h 4Eh 50h 55h 54h 0Dh
Image mode	STANDARD	IMAGE=STANDARD<CR>	49h 4Dh 41h 47h 45h 3Dh 53h 54h 41h 4Eh 44h 41h 52h 44h 0Dh
	PRESENTATION	IMAGE=PRESENTATION<CR>	49h 4Dh 41h 47h 45h 3Dh 50h 52h 45h 53h 45h 4Eh 54h 41h 54h 49h 4Fh 4Eh 0Dh
	VIVID PHOTO	IMAGE=VIVID_PHOTO<CR>	49h 4Dh 41h 47h 45h 3Dh 56h 49h 56h 49h 44h 5Fh 50h 48h 4Fh 54h 4Fh 0Dh
	PHOTO sRGB	IMAGE=PHOTO_SRGB<CR>	49h 4Dh 41h 47h 45h 3Dh 50h 48h 4Fh 54h 4Fh 5Fh 53h 52h 47h 42h 0Dh
	DYNAMIC	IMAGE=DYNAMIC<CR>	49h 4Dh 41h 47h 45h 3Dh 44h 59h 4Eh 41h 4Dh 49h 43h 0Dh
	VIDEO	IMAGE=VIDEO<CR>	49h 4Dh 41h 47h 45h 3Dh 56h 49h 44h 45h 4Fh 0Dh
	CINEMA	IMAGE=CINEMA<CR>	49h 4Dh 41h 47h 45h 3Dh 43h 49h 4Eh 45h 4Dh 41h 0Dh
Image mode	USER1	IMAGE=USER_1<CR>	49h 4Dh 41h 47h 45h 3Dh 55h 53h 45h 52h 5Fh 31h 0Dh
	USER2	IMAGE=USER_2<CR>	49h 4Dh 41h 47h 45h 3Dh 55h 53h 45h 52h 5Fh 32h 0Dh
	USER3	IMAGE=USER_3<CR>	49h 4Dh 41h 47h 45h 3Dh 55h 53h 45h 52h 5Fh 33h 0Dh
	USER4	IMAGE=USER_4<CR>	49h 4Dh 41h 47h 45h 3Dh 55h 53h 45h 52h 5Fh 34h 0Dh
	USER5	IMAGE=USER_5<CR>	49h 4Dh 41h 47h 45h 3Dh 55h 53h 45h 52h 5Fh 35h 0Dh
Image mode acquisition		GET IMAGE<CR>	47h 45h 54h 20h 49h 4Dh 41h 47h 45h 0Dh
Brightness	Brightness value setting	BRI=< Numerical value><CR>	42h 52h 49h 3Dh < Numeric code> 0Dh
Brightness acquisition		GET BRI<CR>	47h 45h 54h 20h 42h 52h 49h 0Dh
Sharpness	Sharpness value setting	SHARP=< Numerical value><CR>	53h 48h 41h 52h 50h 3Dh < Numeric code> 0Dh
Sharpness acquisition		GET SHARP<CR>	47h 45h 54h 20h 53h 48h 41h 52h 50h 0Dh
Contrast	Contrast value setting	CONT=< Numerical value ><CR>	43h 4Fh 4Eh 54h 3Dh < Numeric code> 0Dh
Contrast acquisition		GET CONT<CR>	47h 45h 54h 20h 43h 4Fh 4Eh 54h 0Dh
Aspect	Auto	ASPECT=AUTO<CR>	41h 53h 50h 45h 43h 54h 3Dh 41h 55h 54h 4Fh 0Dh
	4:3	ASPECT=4:3<CR>	41h 53h 50h 45h 43h 54h 3Dh 34h 3Ah 33h 0Dh
	16:9	ASPECT=16:9<CR>	41h 53h 50h 45h 43h 54h 3Dh 31h 36h 3Ah 39h 0Dh
	Zoom	ASPECT=ZOOM<CR>	41h 53h 50h 45h 43h 54h 3Dh 5Ah 4Fh 4Fh 4Dh 0Dh
	Real	ASPECT=TRUE<CR>	41h 53h 50h 45h 43h 54h 3Dh 54h 52h 55h 45h 0Dh
	Full	ASPECT=FULL<CR>	41h 53h 50h 45h 43h 54h 3Dh 46h 55h 4Ch 4Ch 0Dh
Aspect		GET ASPECT<CR>	47h 45h 54h 20h 41h 53h 50h 45h 43h 54h 0Dh
Lamp mode	Standard	LAMP=NORMAL<CR>	4Ch 41h 4Dh 50h 3Dh 4Eh 4Fh 52h 4Dh 41h 4Ch 0Dh
	Quiet	LAMP=SILENT<CR>	4Ch 41h 4Dh 50h 3Dh 53h 49h 4Ch 45h 4Eh 54h 0Dh
Lamp mode acquisition		GET LAMP<CR>	47h 45h 54h 20h 4Ch 41h 4Dh 50h 0Dh
Blank	Execute	BLANK=ON<CR>	42h 4Ch 41h 4Eh 4Bh 3Dh 4Fh 4Eh 0Dh
	Cancel	BLANK=OFF<CR>	42h 4Ch 41h 4Eh 4Bh 3Dh 4Fh 46h 46h 0Dh
Blank acquisition		GET BLANK<CR>	47h 45h 54h 20h 42h 4Ch 41h 4Eh 4Bh 0Dh

## ■ Precautions when installing/using

High wattage lamps are used in the projector, and it becomes very hot. Take care as follows.

- (1) Do not set anything on top of the projector. Also do not project with projectors stacked directly on top of each other.
- (2) Secure space of at least 0.5 meter from the exhausts vents of the projector.
- (3) When using stack projection, secure the following space. Open up the lens side as shown below. Secure the same space also when operating any one of them and stacking and installing one for backup.
- (4) Do not block the intake and exhaust vents of the projector.  
Also, install the projector so that the intake and exhaust vents are not subjected directly to warm air and cold air of air conditioning.
- (5) When operating the projector inserted in a box, ensure that the ambient temperature within the box during operation is within the range of 5°C to 35°C. Also, do not block the intake and exhaust vents. Even when the ambient temperature is 35°C or lower, the protection circuit of the projector may function and shut down the projector due to internal retention of the exhaust heat. Sufficiently consider the ambient temperature environment when installing the projector.

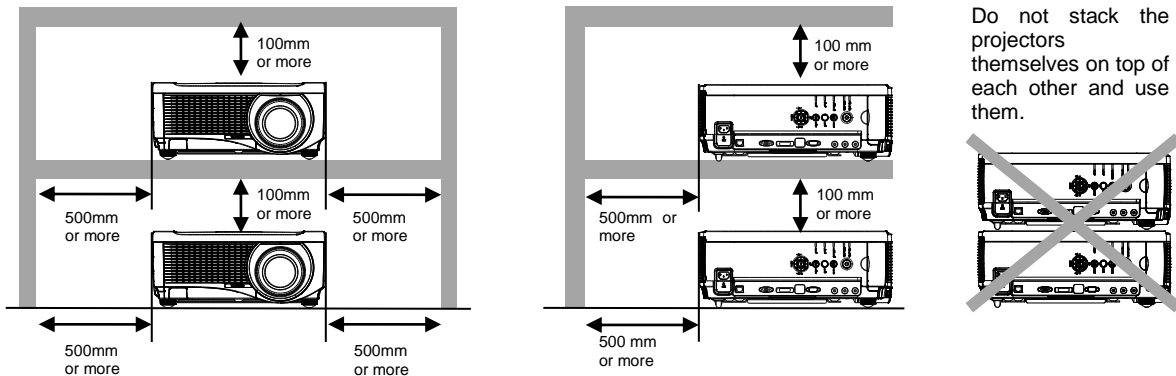

## ■ Concerning the direction of intake/exhaust vents, attachment of optional 2 rear mounting feet

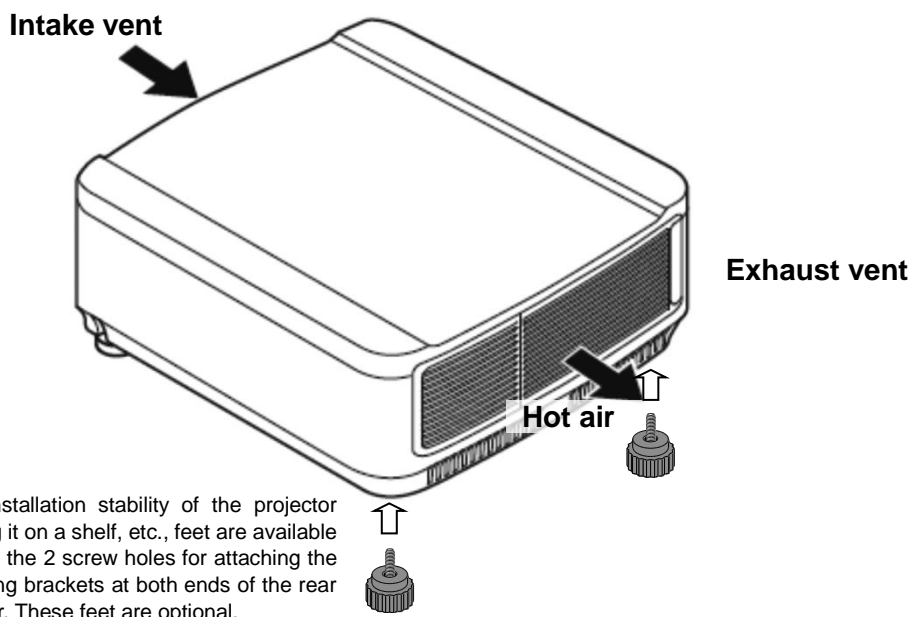

## ■ Concerning replacement of the filter unit

The estimated replacement time for the filter unit is about 3,000 hours. However, that time is only an estimate, and you may need to replace the filter unit sooner depending on your usage environment.

When replacing the filter unit, please purchase RS-FL01.